

Power

Cordex™ 250W

Modular Switched Mode Rectifier

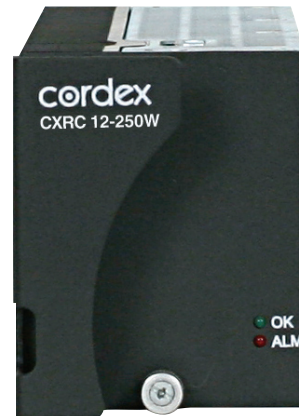

CXRC 12-250W

- Available in 20.8A @ 12VDC
- Universal 120/208 to 240VAC input
- Power factor correction
- Convection cooled
- Hot swappable, 2RU ultra compact design

Cordex rectifiers bring advanced technology to the DC power industry. Innovative engineering combines the best in efficiency and reliability meeting the power requirements for a variety of system applications.

The Cordex 250W rectifier is available in a 19" integrated shelf configuration, complete with distribution, controller, and capacity for four rectifiers. With 1kW total output per shelf, it is an ideal solution for applications requiring 12VDC power.

Local and remote setup, adjustment, and control is a simple single-step process with the Cordex CXCI System Controller. By utilizing TCP/IP technology, complete configuration and monitoring of power equipment is possible through a network web browser.

Cordex 250W Modular Switched Mode Rectifier

Rectifier Module(s)

Electrical

Input voltage:	90 to 320VAC
Power output:	250W
Input frequency:	45 to 70Hz
Power factor:	>99%
THD:	<5%
Efficiency:	>85% @ 204-240VDC (>84% @ 120VDC)
Output voltage:	10.5 to 14.5VDC
Output current:	18.5A @ 13.5VDC (20A max.)
Load regulation:	<±1.5% (static)
Line regulation:	<±0.1% (static)
Transient Response:	±10% for 50 to 100% load step, 10ms recovery time
Wide band noise:	<10mVrms
Psophometric noise:	<100mVp-p <2mV

Mechanical

Dimensions	
mm:	88.4H x 71.6W x 242D
inches:	3.4H x 2.8W x 9.5D
Weight:	1.4kg (3lb)

Features

Indicators:	AC mains OK—green LED Module alarm—red LED
Cooling:	Natural convection
Adjustments: (via CXCI Controller)	Float and equalize voltage Battery test voltage High and low voltage alarms High voltage shutdown Current limit Start delay time Slope %
Protection:	Current limit/short circuit Input/output fuses Output high voltage shutdown Output power limiting Thermal foldback/shutdown Input transient AC low line foldback/shutdown AC high voltage shutdown

Environmental

Temperature	
Operation:	-40 to 50°C (-40 to 122°F) (power derated up to 70°C/158°F)
Storage:	-40 to 85°C (-40 to 185°F)
Humidity:	0 to 95% RH non-condensing
Elevation:	-500 to 3000m (-1640 to 9840ft)
Heat dissipation:	<150 BTU per hour

Shelves

Mechanical

19" shelf	
Dimensions	
mm:	88.9H x 444W x 279.4D
inches:	3.5H x 17.5W x 11D
Weight:	8.5kg (18.7lb)
Mounting:	Fits 19" rack flush/center mount Fits 23" rack center mount

Note: Consult factory for other 12" and 19" shelf configurations.

Connections

Input:	Dual feed terminal blocks 4 to 6mm ² (12 to 10AWG)
Output:	¼" studs on ½" centers
Chassis ground:	¼" stud
CAN communication:	RJ 12 offset

Standards

The Cordex 250W is designed to meet the following:

Safety:	CSA C22.2 No 60950-1-03 UL 60950-1 1 st Edition CE marked IEC/EN 60950-1
EMC:	ETSI 300 386
Emissions:	CFR47 (FCC) Part 15 Class B ICES-03 Class B EN55022 (CISPR 22) Class B C-tick (Australia) EN 61000-3-2 EN 61000-3-3 EN 61000-4-2 EN 61000-4-3 EN 61000-4-4 EN 61000-4-5 EN 61000-4-6 EN 61000-4-11
Immunity:	ANSI/IEEE C62.41 Cat B3

**Cordex 12-250W
19" Integrated Shelf System
Up to 1000W with CXCI and Distribution**

030-820-B2
(030-770-20 pre-RoHS)

The following documents and drawings are included in this manual to provide the necessary information required for installation, operation and fault diagnosis of the unit:

- **Warranty Policy:** 048-507-10
- **Specifications, Rectifier:** 010-613-B1 (010-587-B1 pre-RoHS)
- **Specifications, Shelf:** 030-820-B1
- **Specifications, CXCI:** 707-492-B1
- **CSA/NRTL Equivalence:** 048-554-10
- **Installation and Operation Instructions:** 030-820-C0
- **Schematic Drawing:** 030-770-05 (RoHS: 030-820-20)
- **Outline Drawing:** 030-770-06 (RoHS: 030-820-20)
- **Customer Connections:** 030-770-08 (RoHS: 030-820-20)
- **Factory Service Information:** 048-527-10

WARRANTY AND REPAIR INFORMATION

Warranty Policy

Argus Technologies Ltd. warrants all equipment manufactured by it to be free from defects in parts and labor, excluding third party OEM materials (example: air conditioners, batteries), for a period of two years from the date of shipment from the factory. For third party products the OEM's warranty shall apply. The liability of Argus applies solely to repairing, replacing or issuing credit (at Argus' sole discretion) for any equipment manufactured by it and returned by the customer during the warranty period. The terms of the warranty are Ex Works (EXW) from Argus' factory service location.

Argus reserves the right to void the warranty if:

- (1) identification marks or serial numbers are removed or altered in any way,
- (2) invoice is unpaid, or
- (3) defect is the result of misuse, neglect, improper installation, environmental conditions, non-authorized repair, alteration or accident.

Argus shall not be liable to the customer or other parties for any loss of profits, loss of use, costs for removal or installation of defective equipment, damages or consequential damages based upon equipment failure during or after the warranty period. There shall be no other obligations either expressed or implied. Argus will not honor warranties for batteries and other third party products without prior written Argus authorization.

Freight Policy

Customer is responsible for all shipping and handling charges (COD and freight collect will not be accepted without prior approval from Argus Technologies).

Terms of Payment (North America)

Payment terms are net 30 days subject to prior credit approval. All other orders require payment before shipping.

Terms of Payment (International)

Payment terms are subject to prior approval and are typically through Tele-Transfer.

Return Material Policy

Our RMA policy is designed to ensure prompt, efficient and high quality factory service. A Return Material Authorization (RMA) number must be obtained before products can be accepted for servicing by the Argus factory. For returns to an authorized service center (refer to "Authorized Service Centers" for locations), please consult the individual service center for specific return policies and instructions.

To obtain a RMA number for a factory return, customers must call the appropriate location with the product serial and model number, as well as a brief description of the problem, shipment instructions and billing details.

The original packing container should be used whenever possible. Both the shipping documents and the outside of the box must have the RMA # clearly marked and the product shipped prepaid to the Argus factory service center. Argus will endeavor to repair products within five working days of receipt. Repairs to the returned product are warranted for a period of six months. A service charge may be applied if no fault is found in the returned product. Argus will not accept products without an RMA number.

Business Hours

Argus North American office hours are 7:30 am to 5:00 pm (Pacific Standard Time) Monday to Friday.

Factory Service Centers

Canada and International

Argus Technologies Ltd.
ATTN: RMA Returns
7033 Antrim Avenue
Burnaby, BC, V5J 4M5 Canada
Tel: +1 604 436 5900
Fax: +1 604 436 1233
Email: returns@argusdcpower.com

USA

Argus Technologies Inc.
ATTN: RMA Returns
3116 Mercer Avenue
Bellingham, WA, 98225 USA
Tel: +1-360 756 4904
Fax: +1-360 647 0498
Email: returns-usa@argusdcpower.com

Asia-Pacific

PCM Electronics (Dong Guan) Co., Ltd.
Hongli Industrial Area, Miaobian, Liaobu Town,
Dongguan City, Guangdong Province,
523400 China
Tel: +86 755 8895 3310
Fax: +86 755 8895 3307

Authorized Service Center

Argentina

Argus Technologies de Argentina
Belen 315, Capital Federal, Buenos Aires,
14071 Argentina
Tel: +54 (11) 4672 4821
Fax: +54 (11) 4504 4698
Cell: +54 9 (11) 4993 9996
Email: lkleiman@argus.ca

Asia

Argus Technologies Asia Pte Ltd
Blk 6 Tagore Lane #160
Singapore 787570
Tel: +65 6458 8900
Fax: +65 6458 2122

Australia

CPS National
8/376 Newbridge Rd
Moorebank, NSW, 2170 Australia
Tel: +61 02 9822 8977
Fax: +61 02 9822 8077

Australia/New Zealand

Alpha Power Systems Pty Ltd
Unit 3, 30 Heathcote Road
Moorebank, NSW, 2170 Australia
Tel: +61 02 9602 8331
Fax: +61 02 9602 9180

Century Yuasa

37 - 65 Colbalt Street
Carole Park QLD 4300
Australian Sales & Service
Tel: +61 07 3361 6587
Fax: +61 07 3361 6705
New Zealand Sales & Service
Tel: +64 9 978 6689
Fax: +64 9 978 6677

Canada

Compower Systems Inc.
118 Tiffield Road
Toronto, ON, M1V 5N2 Canada
Tel: +1 416 293 3088
Fax: +1 416 293 0671

Europe

Alpha Technologies Europe Ltd.
Cartel Business Estate
Edinburgh Way
Harlow, Essex, CM20 2DU UK
Tel: +44 1279 422110
Fax: +44 1279 423355

Mexico & Central America

Technologies Argus First De Mexico SA de CV
Anatole France No. 17
Col. Polanco
Mexico City, 11560 Mexico
Tel: +52 55 5280 6990
Fax: +52 55 5280 6585

South America

Argus Technologies Argentina
Santo Tome 2573, Capital Federal
Buenos Aires, 1416 Argentina
Tel: +54 11 4504 4698
Cell: +54 9 11 4993 9996
E-pager: 541149939996@nextel.net.ar

Turkey

IPC Enerji Elk San ve TIC AS
Inonu cad. Kanarya sok. No:20
Yenisahra - Kadikoy
Istanbul, Turkey
Tel: +90 216 317 41 42
Fax: +90 216 472 90 66

Specifications for Argus' Switched Mode Rectifier Cordex 12-250W

Power Module Output

Voltage:	10.5 to 14.5Vdc within rated limits
Current:	18.5A @ 13.5Vdc nominal (20.8A maximum @ 12V)
Maximum Power:	250W continuous/module 246W continuous/module with paralleling diode
Static Load Regulation:	Better than $\pm 1.5\%$ for any load change within rated limits
Static Line Regulation:	Better than $\pm 0.1\%$ for any change in input voltage within rated limits
Dynamic Line Regulation:	Better than $\pm 1\%$ for any change in input voltage within rated limits (output voltage shall recover to static limits within 2ms)
Hold-up Time:	>15ms
Time Stability:	$\leq 0.2\%$ per year
Temperature Stability:	<100ppm/ $^{\circ}\text{C}$ over the operating range
Heat Dissipation:	<152 BTU per hour (per rectifier module)
Electrical Noise:	<32dBnC (voice band) <10mVrms 10kHz to 100MHz (wideband) <100mVp-p to 100MHz <1.0mV (psophometric)
Acoustic Noise:	<55dBa @ 1m (3ft.) @ 30 $^{\circ}\text{C}$ (86 $^{\circ}\text{F}$)
EMI:	The unit meets requirements of EN55022 (see Standards for more EMC)

In accordance with FCC requirements, we provide the following statement as specified in the FCC guidelines for conformance to Part 15, Class B:

NOTE: *This equipment has been tested and found to comply with the limits for a Class B digital device, pursuant to part 15 of the FCC Rules. These limits are designed to provide reasonable protection against harmful interference in a residential installation. This equipment generates, uses, and can radiate radio frequency energy and, if not installed and used in accordance with the instructions, may cause harmful interference to radio communications. However, there is no guarantee that interference will not occur in a particular installation. If this equipment does cause harmful interference to radio or television reception, which can be determined by turning the equipment off and on, the user is encouraged to try to correct the interference by one or more of the following measures:*

- Reorient or relocate the receiving antenna.
- Increase the separation between the equipment and receiver.
- Connect the equipment into an outlet on a circuit different from that to which the receiver is connected.
- Consult the dealer or an experienced radio/TV technician for help.

Any changes or modifications to this equipment not expressly described in this manual could void the FCC compliance.

Specifications for Argus' Switched Mode Rectifier Cordex 12-250W Continued

Power Module Input

Voltage:	90 to 320Vac
Frequency:	45 to 70Hz
Current:	2.5A @ 120Vac 1.2A @ 240Vac (maximum)
Power Factor:	>0.99 at nominal conditions and 50-100% load
Protection:	10kA-interrupting capacity fuses in active and neutral lines
Efficiency:	>85% @ 240Vac for 50-100% load (1% less with OR-ing MOSFET) >84% @ 120Vac for 50-100% load (1% less with OR-ing MOSFET)
Inrush Current:	≤ full load steady state current
Start-up Ready Time:	<5 seconds (excluding soft start)
Start-up Delay:	≤120 seconds (programmable)
Soft Start:	≤10 seconds (user adjustable, not including start-up)
Input Transient Suppression:	Meets ANSI/IEEE C62.41 Category B3
Input Leakage Current:	<3.5mA @ 265Vac 60Hz

Environmental

Operating Temperature:	-40 to +50°C, power derated up to 70°C (-40 to 122°F, power derated up to 158°F)
Storage Temperature:	-50 to +85°C (-58 to 185°F)
Humidity:	0 to 95% non-condensing
Elevation:	-500m to +3000m (-1640 feet to 9840 feet)

Miscellaneous

MTBF:	>405,000 hours ground benign, natural convection >530,000 hours ground benign, forced convection cooled
Dimensions:	88.4mm H x 71.6mm W x 242mm D, excluding connector (3.4" H x 2.8" W x 9.5" D)
Weight:	2.9 kg (6.4 lb.)

Referenced Standards

EN 300 386-2	EMC and ERM; Telecommunication Network Equipment
EN 55022 (CISPR 22): 1998	Information Technology Equipment – Radio Disturbance Characteristics – Limits and Methods of Measurement, Class B
EN 61000-3-2:2000	Harmonic Current Emissions
EN 61000-3-3:1995	Voltage Fluctuations and Flicker
EN 61000-4-2	ESD Immunity
EN 61000-4-3	Radiated Electromagnetic Immunity
EN 61000-4-4	Electrical Fast Transient/Burst Immunity
EN 61000-4-5	Power Line Surge Immunity
EN 61000-4-6	Conducted Electromagnetic Immunity
EN 61000-4-11	Voltage Dips, Short Interruptions and Variations
ETS 300 019-1-1	Environmental Conditions; Storage
ETS 300 019-1-2	Environmental Conditions; Transportation
ETS 300 132-2	Power Supply Interface at the Input to Telecommunications Equipment; Operated by Direct Current (DC)
ETS 300 753	Acoustic Noise Emissions
IEC 60950	Safety of Information Technology Equipment, Including Electrical Business Equipment (UL/CSA 60950)

The above information is valid at the time of publication. Consult factory for up-to-date ordering information. Specifications are subject to change without notice.

Specifications for Argus' Cordex 12-250W 19" Integrated Shelf System

Basic Unit, Shelf

Maximum Output:	84A, 15Vdc
Recommended Feeder Breaker Single Phase:	10A, #14AWG [for up to two (2) rectifiers]

Mechanical

Dimensions:	88mm H x 444mm W x 307mm D (rectifier front panel 18mm D) [3.5" H x 17.5" W x 12.1" D (rectifier front panel 0.7" D)]
Mounting*:	19" or 23" rack (flush or 5" offset or 6" offset)
Weight:	8.5 kg (18.7 lb.)

Connections

AC Input:	Dual feed terminal blocks 4 to 6mm ² (#12 to #10AWG)
Chassis ground:	M4 studs
Communications:	CAN (bus) out RJ-12 offset
DC Output:	Terminal blocks 16mm ² (#6AWG) maximum
Signal wiring:	Terminal blocks 0.129 to 0.823mm ² (#26 to #18AWG)

Safety

EN 60950	Rectifier output shall be rated SELV suitable for connection to TNV-1 circuits
UL	60950-1-2002
CSA	C22.2 No. 60950
CE	EN 60950, CB Scheme 73/23/EEC Low Voltage Directive with amendment 93/68/EEC
Telcordia (Bellcore)	GR-1089-CORE (requirements applicable to rectifier)

* See drawings at the rear of this manual.

The above information is valid at the time of publication. Consult factory for up-to-date ordering information. Specifications are subject to change without notice.

SPECIFICATIONS FOR ARGUS' CXCI CORDEX CONTROLLER INTEGRATED MODEL

Basic Unit, CXCI

Input Voltage:	17 to 65Vdc within rated limits [9 to 65Vdc for shelf systems with 12V rectifiers (List 3)]
Current:	<100mA @ 48Vdc <200mA @ 24Vdc
MTBF:	472,000 hours @ 25°C (77°F)
EMC:	The unit meets requirements of: ICES-003 Class B EN 55022 Class B (CISPR 22) EN 61000-4-2 ESD EN 61000-4-3 Radiated Immunity EN 61000-4-4 EFT /Burst EN 61000-4-6 Conducted Immunity FCC Part 15 Class B, FCC Part 68

In accordance with FCC requirements, we provide the following statement as specified in the FCC guidelines for conformance to Part 15, Class B:

NOTE: *This equipment has been tested and found to comply with the limits for a Class B digital device, pursuant to part 15 of the FCC Rules. These limits are designed to provide reasonable protection against harmful interference in a residential installation. This equipment generates, uses, and can radiate radio frequency energy and, if not installed and used in accordance with the instructions, may cause harmful interference to radio communications. However, there is no guarantee that interference will not occur in a particular installation. If this equipment does cause harmful interference to radio or television reception, which can be determined by turning the equipment off and on, the user is encouraged to try to correct the interference by one or more of the following measures:*

- Reorient or relocate the receiving antenna.
- Increase the separation between the equipment and receiver.
- Connect the equipment into an outlet on a circuit different from that to which the receiver is connected.
- Consult the dealer or an experienced radio/TV technician for help.

Any changes or modifications to this equipment not expressly described in this manual could void the FCC compliance.

Environmental

Temperature:	-40 to 65°C standard @ 3000m derate to 55°C @ 4000m (-40 to 149°F derate to 131°F @ 13124ft)
Humidity:	0 to 95% non-condensing
Elevation:	-500 to +4000m (-1640 to 13124 ft)

Hardware Specifications, CXCI

CPU:	Coldfire
RAM:	8MB
Flash:	4MB standard
Display:	4 digit LCD
Front Panel Controls:	Display pushbutton toggle switch for voltage (V) or current (A) CXCI reset switch (soft reset button; hold for 3 seconds to reset IP)
LED's:	System OK (Green) Power System Minor Alarm (Yellow) Power System Major Alarm / Controller Fail (Red)
Audio:	Built-in speaker for alarm and popup message tones
Dimensions:	88mm H x 26mm W x 280mm D (3.5" H x 1" W x 11" D)
Weight:	0.34 kg (0.75 lb.)
Mounting:	Integrated on Cordex 2RU series 19" and 23" shelves
Relay Outputs:	Four (4) Form C, 60Vdc 1A maximum
Digital Inputs:	Two (2), 0 to 60Vdc
Analog Inputs:	One (1) DC voltage, 0 to 60Vdc One (1) DC current, $\pm 50\text{mV}$ Two (2) temperature, 0 to 20Vdc with power source
Communication Ports:	Ethernet RJ-45, Modem RS-232 DB-9, CAN [see shelf specifications]

Recommended Signal Wire Sizes (as per UL/CSA)

Wire Size Range:	0.129 to 0.823mm ² (#26 to #18 AWG)
Temperature Range:	0 to 50°C (32 to 122°F)

CAUTION – TO REDUCE RISK OF FIRE, USE ONLY 0.129mm² (#26 AWG) OR LARGER WIRE.

The above information is valid at the time of publication. Consult factory for up-to-date ordering information. Specifications are subject to change without notice.

MANUAL ADDENDUM

Unit Description: CORDEX INTEGRATED SHELF WITH CXCI

Documents Affected P/N: 030-728-C0, 030-752-C0, 030-763-C0, 030-773-C0, 030-776-C0, 030-781-C0, 030-782-C0, 030-807-C0, 030-815-C0, 030-818-C0, 030-820-C0, 034-108-C0, 707-492-B1

Date	Correction to be implemented
07-10-26	Add text: CAUTION Do not connect anything other than the Argus modem and Argus-supplied DB-9 cable to the D-sub port on the front of the CXCI.

MANUAL ADDENDUM

CSA/NRTL — MARKS — BACKGROUND

What are the CSA and NRTL?

CSA (Canadian Standards Association also known as CSA International) was established in 1919 as an independent testing laboratory in Canada. CSA received its recognition as an NRTL (Nationally Recognized Testing Laboratory) in 1992 from OSHA (Occupational Safety and Health Administration) in the United States of America (Docket No. NRTL-2-92). This was expanded and renewed in 1997, 1999, and 2001. The specific notifications were posted on OSHA's official website as follows:

- Federal Register #: 59:40602 - 40609 [08/09/1994]
- Federal Register #: 64:60240 - 60241 [11/04/1999]
- Federal Register #: 66:35271 - 35278 [07/03/2001]

When these marks appear with the indicator "C and US" or "NRTL/C" it means that the product is certified for both the US and Canadian markets, to the applicable US and Canadian standards. (1)

Argus rectifier and power system products, bearing the aforementioned CSA marks, are certified to CSA C22.2 No. 950 and UL 1950, or CSA/UL 60950.

As part of the reciprocal, US/Canada agreement regarding testing laboratories, the Standards Council of Canada (Canada's national accreditation body) granted Underwriters Laboratories (UL) authority to certify products for sale in Canada. (2)

Only Underwriters Laboratories may grant a licence for the use of this mark, which indicates compliance with both Canadian and US requirements. (3)

What are NRTLs and what do they do?

NRTLs are third party organizations recognized by OSHA, US Department of Labor, under the NRTL program.

The testing and certifications are based on product safety standards developed by US based standards developing organizations and are often issued by the American National Standards Institute (ANSI). (4)

The NRTL determines that a product meets the requirements of an appropriate consensus-based product safety standard either by successfully testing the product itself, or by verifying that a contract laboratory has done so, and the NRTL certifies that the product meets the requirements of the product safety standard. (4)

When was the NRTL started and who governs it?

In 1983, in a suit brought on by an independent testing laboratory, OSHA was court ordered to remove specific references to UL (Underwriters Laboratories) and FMRC (Factory Mutual Research Corporation) from its regulations.

In 1988, OSHA revised its regulations to remove those references and the NRTL program was established.

The NRTL Program is both national and international in scope with foreign labs permitted.

References:

Information in this document has been developed from the official websites of the respective organizations.

- (1) www.csa-international.org
- (2) www.scc.ca
- (3) www.ulc.ca
- (4) www.osha.gov



The product on which either of these marks appear has been certified by CSA as meeting applicable Canada/US standards.



The product on which this mark appears has been certified by UL as meeting applicable Canada/US standards.

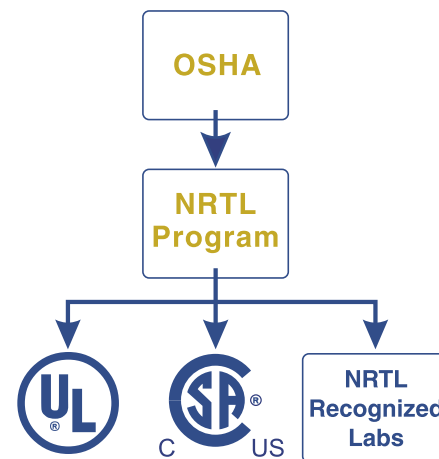

IMPORTANT SAFETY INSTRUCTIONS

SAVE THESE INSTRUCTIONS

1. Please read this manual prior to use to become familiar with the product's numerous features and operating procedures. To obtain a maximum degree of safety, follow the sequences as outlined.
2. This manual provides warnings and special notes for the user:
 - a. Points that are vital to the proper operation of the product or the safety of the operator are indicated by the heading: **WARNING**.
 - b. A notation that is in ***Bold Italic*** typeface covers points that are important to the performance or ease of use of the product.
3. Before using the product, read all instructions and cautionary markings on the product and any equipment connected to the product.
4. Do not expose the product to rain or snow; install only in a clean, dry environment.
5. **CAUTION** – Unless otherwise noted, use of an attachment not recommended or sold by the product manufacturer may result in a risk of fire, electric shock, or injury to persons.
6. **CAUTION** – Do not operate the product if it has received a sharp blow, it has been dropped, or otherwise damaged in any way – return it to a qualified service center for repair.
7. **CAUTION** – Do not disassemble the product – call our qualified service centers for servicing. Incorrect reassembling may result in a risk of electrical shock or fire.

This page intentionally left blank.

TABLE OF CONTENTS

1	INTRODUCTION	1
1.1	Scope of the Manual	1
1.2	Product Overview	1
1.3	Part Numbers and List Options	2
2	FEATURES	3
2.1	Cordex Integrated System Controller (CXCI)	3
2.2	System Controller Front Panel	3
2.3	Analog Input Channels	4
2.4	Digital Input Channels	5
2.5	Alarm and Control Output Relays	5
2.6	Network Connection and Remote Communications via CXCI	5
2.7	Rectifier Front Panel	5
2.8	True Module Fail Alarm	6
2.9	Heat Dissipation	6
2.10	Over Temperature Protection	6
2.11	Wide AC Range	6
2.12	AC Inrush/Transient Suppression	7
2.13	Soft Start	7
2.14	Start Delay	7
2.15	Current Limit/Short Circuit Protection	7
2.16	Power Limiting	7
2.17	High Voltage Shutdown (HVSD)	7
2.18	Battery Eliminator Operation	7
3	INSPECTION.....	8
3.1	Packing Materials	8
3.2	Check for Damage	8
4	INSTALLATION	9
4.1	Safety Precautions	9
4.2	Shelf Preparation/Mounting	9
4.3	Module Insertion/Removal	9
5	WIRING AND CONNECTIONS	10
5.1	Safety Precautions	10
5.2	Tools Required	10
5.3	Power System Chassis Ground and DC Ground Reference	10
5.4	AC Feeder Protection/Sizing	10
5.5	AC Input Connections	11
5.6	Calculating Output Wire Size Requirements	11
5.7	DC Output Connections	11
5.8	CAN Out Port	12
5.9	Network Connection and Remote Communications via CXCI	12
5.10	Signal Wiring Connections	12
6	OPERATION.....	15
6.1	Main Rectifier States	15
6.2	Main Rectifier Modes	16
6.3	Can Bus Communications	16

6.4	Factory Ranges and Defaults	17
7	SYSTEM STARTUP	18
7.1	Check System Connections.....	18
7.2	Verify AC and Power the Shelf	18
7.3	Check Battery Polarity and Connect.....	18
7.4	CXC Reset	18
8	MAINTENANCE	19
8.1	CXCI Replacement Procedure.....	19
9	ARGUS CONVENTIONS.....	21
9.1	Numbering System.....	21
9.2	Acronyms and Definitions	21

1 Introduction

1.1 Scope of the Manual

This instruction manual explains the installation, interconnection, and operation of Argus Technologies' Cordex 12-250W integrated 19" 2RU shelf system with up to 1000W output power and distribution.

NOTE: *To aid the user with installation, frequent reference is made to drawings located at the rear of the manual.*

1.2 Product Overview

A complete Cordex rectifier system consists of a controller with one or more power modules in a common shelf enclosure. The shelf has connections for AC inputs, DC output, and system communications.

Cordex rectifier modules use a high frequency, switched mode conversion technique to provide a fully regulated and isolated DC output from the AC mains. The rectifier input is wide range to allow use on 120/208/220/240Vac 50/60Hz electrical service.

Rectifier power modules are "hot swappable" meaning they can be inserted or removed from the shelf without cutting power to or from the system or the load.

Additional power modules can be included with the system at the time of ordering or added after the shelf has been installed.

The shelf rectifier system is designed to operate with the Argus Cordex CXCI (integrated version of the CXC controller); which is built into the rectifier system shelf.

Details for installation and wiring are provided in the respective chapters of this documentation package.

All models of the CXC allow the user to set up, control and monitor the entire power system and ancillary components from one central, easy-to-use source: your web browser. The CXCI models do not have a touch screen display; therefore, system setup and management is performed exclusively with the web interface.

Details of controller operation are provided in the current version software manual.

The distribution component utilizes four bullet-type breakers.

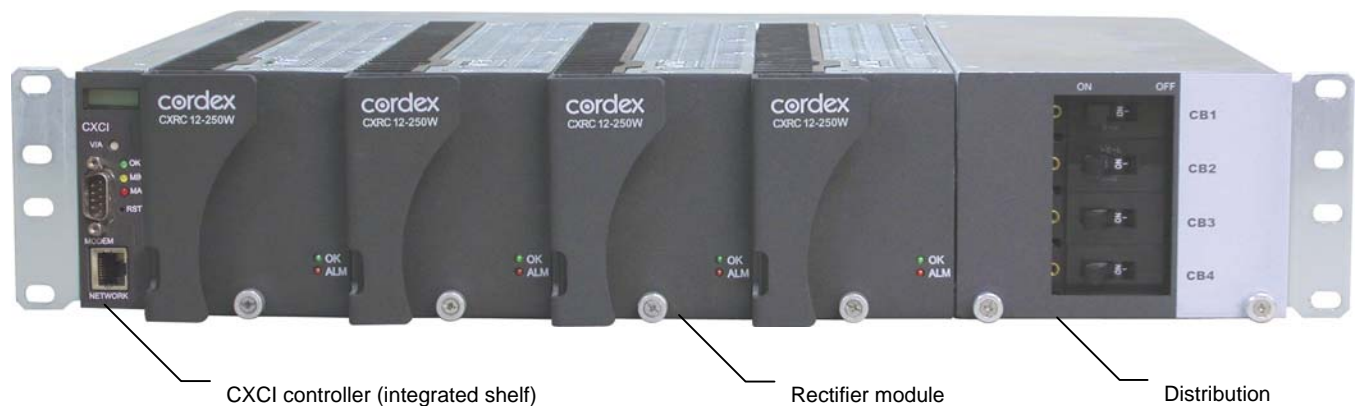

Figure 1–Cordex 12-250W integrated 19" 2RU shelf system

1.3 Part Numbers and List Options

This product is available to order under the following part numbers and list options:

Description	Part Number/List Option
Cordex 12-250W 19" (flush mounting) 2RU shelf for systems up to 1000W (030-770-20 pre-RoHS).....	030-820-20
[equipped to receive one CXCI controller and four CXRC 12-250W rectifiers]	*List 0
12Vdc output	*List 3
120Vac input	List 5
240Vac input	List 6
19" rack, 6" offset mounting	List 19
19" rack, flush mounting	List 21
19" rack, 5" offset mounting	List 22
23" rack, 6" offset mounting	List 23
23" rack, flush mounting	List 25
23" rack, 5" offset mounting	List 26
Charcoal finish with white (contrasting) silkscreen	*List 56
Temperature sensor, 1/4" lug, 12 ft.....	List 72
Temperature sensor, 3/8" lug, 12 ft.....	List 75
Circuit breaker distribution, bullet-type, four load circuit breakers, two battery connections.....	**List 80
Circuit breaker distribution, bullet-type, two load circuit breakers, two battery circuit breakers	**List 84
Load disconnect	List 86
Battery disconnect.....	List 87
Two line cords without plugs, 3m each	List 89
Rectifier blank plate.....	List 90
CXCI controller	*List 99
Breaker, mid-trip, 5A	List 100
Breaker, mid-trip, 10A	List 101
Breaker, mid-trip, 20A	List 102
Breaker, mid-trip, 30A	List 103
Breaker, mid-trip, 40A	List 104
Breaker, mid-trip, 50A	List 105
Breaker, mid-trip, 60A	List 106
Breaker, series-trip, 60A	List 156
Cordex 12-250W rectifier power module (010-587-20 pre-RoHS)	010-613-20
Basic module, 12Vdc output	*List 0
Charcoal finish with white (contrasting) silkscreen	*List 56
Paralleling diode (Oring MOSFET) for operation without battery	List 82

* Default option

** Distribution option requires one of List 80 or 84. NOTE: For effective alarm operation, battery circuit breakers should be series-trip.

The above information is valid at the time of publication. Consult factory for up-to-date ordering information.

2 Features

2.1 Cordex Integrated System Controller (CXCI)

The Cordex CXCI integrated system controller is mounted in the rectifier system shelf and brings advanced monitoring technology to the Cordex series of rectifiers. This compact system controller is designed for seamless operation and set up of Argus power systems and is equipped with the complete range of Cordex software features, including the following:

- Designed to communicate directly with Cordex rectifiers
- Includes battery temperature compensation charging
- Battery performance diagnostics
- Provides local and remote communications
- User definable alarms
- Daily logging of power system events and system statistics.

Behind the CXCI's front panel lies the main controller motherboard, which contains a microprocessor, memory, as well as numerous other electronic components.

The CXCI includes a web server providing easy set up and monitoring using an Internet connection with the standard Windows Internet Explorer browser.

The data logging feature allows the user to capture data from multiple inputs, for AC/DC voltages, load/battery current, cell voltages & temperatures (automatically for up to 16 user defined logs). Typical applications of the CXCI logging include power system details, thermal performance of outdoor enclosures, battery cell specifics, or mains variations captured by an AC voltage watchdog.

A built-in audio speaker sounds an intermittent tone during active alarms.

The input/output (I/O) board houses a series of terminal connections; located at the back of the system shelf.

NOTE: *Customer settings for the CXCI will be provided separately in the system documentation package.*

2.2 System Controller Front Panel

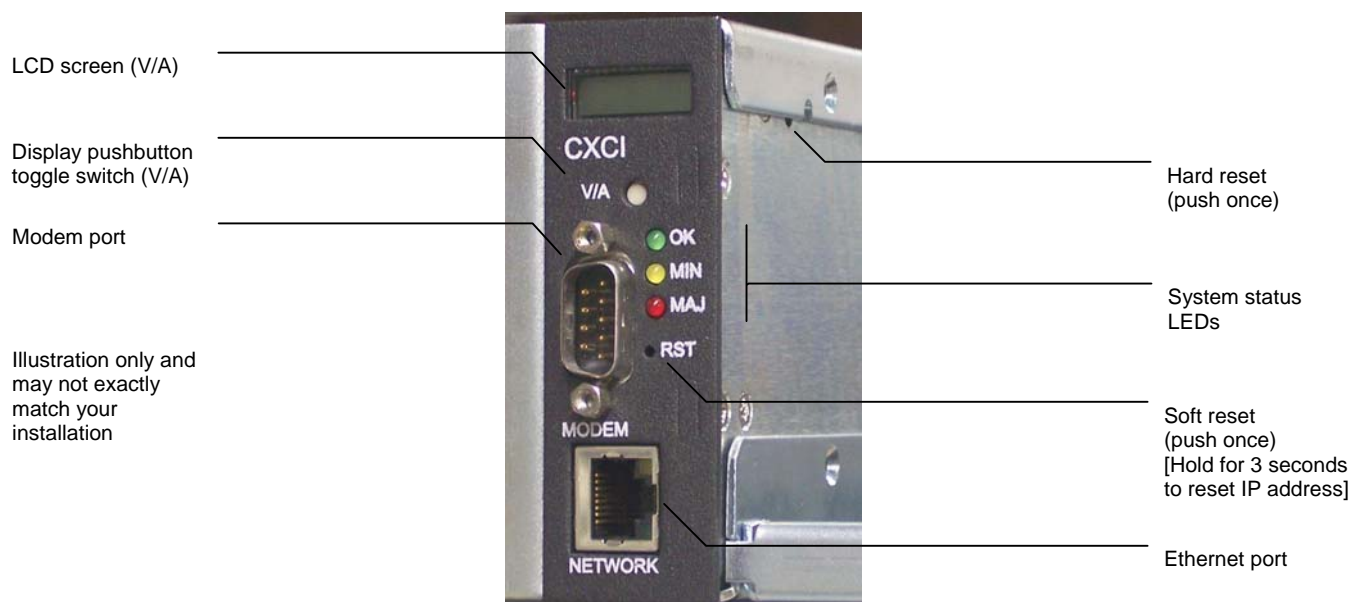

Figure 2–Cordex CXCI model system controller front panel

Details of controller operation are provided in the current version software manual.

2.2.1 Display

The CXCI has a 4-digit display for monitoring system voltage (V) and current (A). A pushbutton toggle switch allows the user to alternate the display reading.

2.2.2 LEDs

The CXC has three LEDs located on the front panel. These are used to display the alarm status of the power system, CXC progress and status during startup, file transfers and lamp tests.

2.2.2.1 Alarm Conditions

The CXC illuminates the LED that corresponds to the system alarm status. The following show the corresponding alarm status for each LED color:

Green – OK, no alarms present

Yellow – Minor alarm is present (no major alarms)

Red – Major alarm is present.

Only one LED is illuminated at a time during alarm conditions.

2.2.2.2 Progress and Status Indication

The LEDs are also used in the following situations:

Base unit validation – all three LEDs are on at the same time.

File transfer – when recovering from invalid firmware application – the red LED is illuminated.

Lamp Test – all three LEDs flash on and off at the same time for 2 seconds.

2.2.3 Reset

A reset button is located on the front panel for restarting the CXC's microprocessor. See Section 7.4.

NOTE: *Refer also to the software manual – always select the Reset menu item before pressing the reset button.*

2.2.4 Modem Port

The Modem port is designed for CXCI connection to a user supplied modem via a front panel DB-9 connector (Figure 2) and a straight through cable. See Argus Technologies' Cordex DC Modem #018-585-20.

2.2.5 Ethernet Port

The Ethernet port is designed for CXC connection to a user supplied network (TCP/IP secured by user) via a front panel RJ-45 jack (Figure 2) and a standard network cable.

Local access (e.g. laptop computer) is also possible from the Ethernet port connection using a standard network crossover cable.

2.3 Analog Input Channels

2.3.1 Voltage Inputs

Two voltage input channels, V1 and V2, provide monitoring of discharge and charge voltage. The CXC software is pre-configured to monitor V1 for load voltage and V2 for battery voltage. V2 (wired internally) is used as the system reference for rectifier float voltage, low voltage disconnect (LVD), system high voltage alarm, and system low voltage alarm.

2.3.2 Current Input

The CXC software is pre-configured to monitor I1 for load current wired internally to the system current shunt.

2.3.3 Temperature Inputs

Two temperature input channels, T1 and T2, provide monitoring of battery temperature and temperature compensation (temp comp) or room/ambient temperature. A voltage is supplied to these terminals to power the temperature sensors.

2.4 Digital Input Channels

The CXCI can accommodate up to two channels and can monitor digital alarm/control signals from rectifiers, converters and many other types of equipment. See Section 5.10.2.

2.5 Alarm and Control Output Relays

The CXCI contains four Form C digital alarm output relays to extend alarms and control external apparatus. Each internally generated alarm or control signal may be mapped to any one of the relays, or, several signals may be mapped to just one relay or none at all. See Section 5.10.3.

2.6 Network Connection and Remote Communications via CXCI

The Cordex system can be set up, monitored and tested via ETHERNET 10/100 Base-T serial data connection. The communication protocol supports a web interface. All alarming and control of Cordex rectifiers is accomplished with a CXC via a CAN bus.

A step-by-step connection wizard – provided to establish remote communications with your CXC – is available via the Argus website (www.argusdcpower.com).

2.7 Rectifier Front Panel

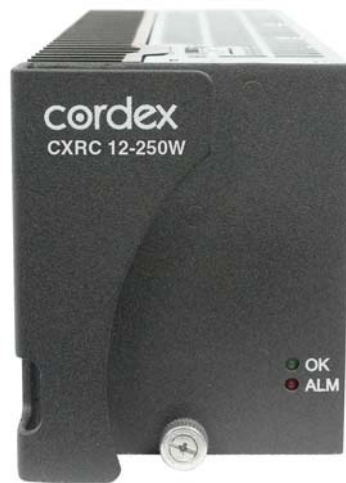

Figure 3–Cordex 12-250W rectifier front panel

2.7.1 LEDs

The front panel LEDs provide rectifier status summary and help to locate a specific module under CXC control.

2.7.1.1 OK

The top LED (green) is on when AC is within valid range and the rectifier is delivering power to the load.

The LED turns off when AC has failed or when the rectifier is off; e.g., when commanded via the CXC. AC voltage is invalid if the AC Mains Low or AC Mains High alarm is active.

2.7.1.2 ALARM

The bottom LED (red) is on continuously in the event of an active Module Fail alarm.

The LED will flash (~2Hz) when a minor alarm is detected.

The LED remains off in the absence of an alarm.

2.7.1.3 LED Activity During 'Locate Module' Command from CXC

When the 'locate module' command has been received from the CXC, the LEDs will behave in a distinctly different way so that the rectifier is easier to visually identify among adjacent rectifiers.

This state is entered when commanded via the CXC. The LEDs will flash in a distinct pattern repeating every 2 seconds.

2.7.1.4 LED Activity During Firmware Upload

When a rectifier firmware upload is in progress, the LEDs will behave in the same way as the 'locate module' command described above.

2.7.2 Mechanical

A thumbscrew is provided to secure the rectifier into the shelf. During normal operation the rectifier shall be locked into position. A handle (or grip) is incorporated into the front panel to facilitate the removal of the rectifier from the shelf. No special tools are required.

2.8 True Module Fail Alarm

The power modules have a "true" fail alarm. This provides a true indication of the power module's ability to source current. When the module's output current drops below 2.5% of the rated output a low output current condition is detected and the Module Fail detection circuit is activated. This circuit momentarily ramps up the output voltage to determine if the module will source current. If no increase in current is detected, the Module Fail alarm is activated. The module will test once every 60 seconds for the condition until current is detected. Output voltage ramping will cease upon detection of current¹. A minimum 2.5% load is required to avoid the Ramp Test Fail alarm; this can typically be provided with the parallel system battery. Activation of this alarm could indicate a failed module or a failed load.

NOTE: *For Cordex rectifier systems without batteries (or with a very light load; below 2.5% of rated output) it is recommended that the ramp test be disabled to avoid nuisance alarms. The Ramp Test feature is enabled/disabled via the CXC menu item: Rectifiers, Configure Settings.*

2.9 Heat Dissipation

Heat dissipation is achieved through natural (bottom to top) convection cooling.

2.10 Over Temperature Protection

Each rectifier module is protected in the event of an excessive increase in temperature due to component failure or cooling airflow blockage. During over temperature conditions, the rectifier limits the output power as well as the output current. If temperature continues to increase, a shutdown of the rectifier is initiated. The rectifier shall restart automatically if the temperature has returned to a safe level.

2.11 Wide AC Range

A minor alarm is generated when the AC input voltage drops below specification. The unit will deliver derated output power down to 80Vac.

For voltages above 277Vac, power factor and total harmonic distortion may be derated. Up to 320Vac, the rectifier will be operational and shall not suffer any damage.

¹ Under normal conditions, a battery connected to the output of the rectifier will draw current when the voltage ramp occurs. Therefore the rectifier fail alarm will not be generated with a battery connected.

2.12 AC Inrush/Transient Suppression

The inrush current of the rectifier module is limited to the full load steady state line current to prevent surge on the AC line. Modules are also protected from input lightning and transient surges in accordance with IEEE/ANSI C62.41 Category B3.

2.13 Soft Start

To eliminate an instantaneous demand on the AC source, a soft start feature is employed. Soft Start, sometimes referred to as “current walk-in”, works by gradually (up to five seconds) ramping the current limit up from zero to the actual or defined customer setting. The rectifier output voltage is ramped up from the minimum voltage to the float voltage.

2.14 Start Delay

The rectifier modules are equipped with a delay timer in order to stagger start a series of modules to prevent excessive loading of generators upon start up. The built-in timer delays the turn on of the module depending on the value selected (up to 120 seconds) via the CXC. A minimum one-second delay is preset to allow charging of the input capacitors.

2.15 Current Limit/Short Circuit Protection

The current limit function determines the maximum output current limit of the rectifier module, regardless of output voltage or power. Maximum output current is limited to a constant value down to short circuit condition. Current limiting can be used to mate the rectifier output current ampacity to the needs of the load and parallel battery to minimize excessive battery recharge current.

The rectifier will sustain a short circuit at the output terminals indefinitely. The maximum short circuit current shall not exceed 105% of the rated full load current.

2.16 Power Limiting

Each rectifier module is designed to limit power output to the module specification. This enables more current to be supplied at lower output voltages, and allows matching of output to the demand of constant power loads, normally seen with telecom equipment.

This feature may also be used for a faster recharge of flooded batteries paralleled with the load.

NOTE: *Current limiting overrides the power-limiting feature.*

2.17 High Voltage Shutdown (HVSD)

This feature provides protection to the load from over voltage conditions originating from the rectifiers. It operates by shutting down the offending rectifier module when a high output voltage condition occurs. Indication is through the red Alarm (Module Fail) LED. Modules will restart automatically; however, if more than three over voltage conditions occur in one minute, the module will latch off and remain shut down until it is reset.

2.18 Battery Eliminator Operation

Rectifier modules maintain all specifications (except where indicated) with or without a battery attached in parallel to the output; however, if a battery or another module supplying DC voltage in parallel is not present, there will be no monitoring or control activity if there is an AC power failure or input fuse failure.

2.18.1 Paralleling Diode (optional)

An optional Oring MOSFET on the output prevents disruption of DC system output power in the event of a rectifier internal fault in systems without batteries.

NOTE: *Maximum output power of a 250W rectifier is reduced to 246W with this option.*

3 Inspection

3.1 Packing Materials

All Argus products are shipped in rugged, double walled boxes and suspended via solid inserts to minimize shock that may occur during transportation. Packaging assemblies and methods are tested to International Safe Transit Association standards.

Products are also packaged with Cortex. This plastic wrap contains a corrosive-inhibitor that protects the product from corrosion for up to two years.

3.1.1 Returns for Service

Save the original shipping container. If the product needs to be returned for service, it should be packaged in its original shipping container. If the original container is unavailable, make sure the product is packed with at least three inches of shock-absorbing material to prevent shipping damage.

NOTE: *Argus Technologies is not responsible for damage caused by the improper packaging of returned products.*

3.2 Check for Damage

Prior to unpacking the product, note any damage to the shipping container. Unpack the product and inspect the exterior for damage. If any damage is observed contact the carrier immediately.

Continue the inspection for any internal damage. In the unlikely event of internal damage, please inform the carrier and contact Argus Technologies for advice on the impact of any damage.



Verify that you have all the necessary parts per your order for proper assembly.

4 Installation

This chapter is provided for qualified personnel to install the product, which shall be mounted in a clean and dry environment.

NOTE: *To aid the user with installation, frequent reference is made to drawings located at the rear of the manual.*

4.1 Safety Precautions



WARNING

Hazardous voltages are present at the input of power systems. The DC output from the rectifiers and battery system, though not dangerous in voltage, has a high short circuit current capacity that may cause severe burns and electrical arcing.

Before working with any live battery or power system/distribution center, follow these precautions:

- Remove all metallic jewelry; e.g., watches, rings, metal rimmed glasses, necklaces.
- Wear safety glasses with side shields (and prescription lenses if necessary) at all times during installation.

Metallic tools must be insulated.

The installer should follow all applicable local rules and regulations for electrical and battery installations; e.g., CSA, UL, CEC, NEC, OSHA, and local fire codes.

4.2 Shelf Preparation/Mounting

The shelf has been designed for flush mounting in a 19" or 23" rack. Universal mounting brackets allow for 5" or 6" offset mounting. The configuration depends on the options chosen. See drawing 030-770-06.

NOTE: *The shelf shall be mounted in a clean and dry environment. Allow at least 1.75" of free space above and below the unit for unrestricted cooling airflow. 3.5" (2RU) is recommended.*

Mounting brackets accommodate either 1" or 1-3/4" rack spacing. The shelf should be mounted to the rack using at least two #12 – 24 x 1/2" screws in each bracket. Philips-type screws and screwdriver should be used to eliminate the possibility of slippage and scratching of the unit's exterior. Washers (such as internal tooth) or special screws that are designed to cut through the painted surface should be used to ensure a good chassis ground.

4.3 Module Insertion/Removal

Insert by placing the module on the shelf bottom and sliding the module into the rear connector (inside of the shelf). Apply pressure on the module handle to engage the rear connector in the shelf receptacle.

NOTE: *It is recommended that the first module be inserted into the front leftmost position using the side of the shelf-mounted controller as a guide. The next module may be inserted using the previous module as a guide.*

Tighten the screw on the bottom of the faceplate to secure the module to the shelf.

NOTE: *Do not force a module into position if it does not seat properly. All modules are keyed to ensure that the correct module (polarity/voltage) type is used.*

To remove a module, loosen the screw on the bottom of the faceplate. Grasp handle and pull out, sliding the module away from the rear connector and out of the shelf.

5 Wiring and Connections

This chapter provides cabling details and notes on cable sizing for DC applications with respect to the shelf.

NOTE: Refer also to foldout drawings located at the rear of the manual.

5.1 Safety Precautions



WARNING

Hazardous AC voltages may be present. Ensure power at the AC service panel is off before attempting work on the AC connections. Use a voltmeter to verify the absence of voltage. Clearly mark the correct polarity of the battery leads before commencing work on DC connections.

Refer to the previous (Installation) chapter for additional safety precautions.

5.2 Tools Required

Various tools are essential for product installation. Use this list as a guide:

- Slot head screwdrivers (blade sizes: 1/4", 1/8", 1/16")
- Philips head screwdriver, #2 (tip size 3/16")
- Digital voltmeter equipped with test leads
- Adjustable 12Vdc load (optional)
- Cutters and wire strippers
- Crimping tool (optional for large gauge wire)
- Socket and ratchet set (Imperial measure)
- Anti-static wrist strap
- Computer (laptop) with Microsoft® Internet Explorer 6 or greater
- Crossover cable RJ-45 (for access using the Ethernet port).

5.3 Power System Chassis Ground and DC Ground Reference

WARNING

For safety reasons, ensure the system is properly bonded to the building's ground grid.

Both the shelf chassis ground (via power system chassis ground) and common return shall be connected to the site ground to ensure correct operation of the system and to prevent drifting floating analog (especially current) readings.

5.4 AC Feeder Protection/Sizing

To maximize system reliability, a dual AC feed divides the rectifiers into two groups to be supplied by two separate feeds. See customer connections drawing (modules are numbered left to right). TB3 feeds modules 1 and 2. TB4 feeds modules 3 and 4.

It is recommended for each feed to use a dedicated protection feeder breaker located at the AC distribution panel. The feeder breaker can also act as the disconnect device for the connected modules.

Number of Rectifiers on AC Feed	Circuit Breaker Exact Value to Use (A)	90 deg. C Wire Gauge to use at 30 deg. C ambient (AWG)
1	10	18
2	10	14

Table A—Recommended AC supply configuration

5.5 AC Input Connections

CAUTION: AC input wires should be routed in flexible or rigid conduit as far away as possible from the DC power wires to minimize EMI disturbances.

If the shelf is factory-equipped with a line cord, proceed to the next section.

Refer to customer connections drawing 030-770-08 (rear view – back cover removed).

Remove the metal cover from the rear of the shelf to expose the wireway for the input terminal blocks.

Attach the conduit retainers to the wireway hole(s) and route the AC cables through. Secure the wires to the AC input and chassis ground terminals as required. Tighten the cable connector to the AC cable (conduit similar).

Replace rear cover once all connections have been completed.

5.6 Calculating Output Wire Size Requirements

Wire size is calculated by first determining the appropriate maximum voltage drop requirement. Using the formula below calculate the CMA wire size requirement. Determine the size and number of conductors required to satisfy the CMA requirement.

$CMA = (A \times LF \times K) / AVD$, where:

CMA = Cross section of wire in circular MIL area

A = Ultimate drain in amps

LF = Conductor loop feet

K = 11.1 constant factor for commercial (TW type) copper wire

AVD = Allowable voltage drop

Check again that the ampacity rating of the cable meets the requirement for the installation application. Consult local electrical codes (NEC, CEC, etc.) for guidelines. If required, increase the size of the cable to meet the code.

5.7 DC Output Connections



WARNING

Leave cables disconnected at battery and verify output polarity using a voltmeter. Make battery connections only after all other wiring is completed.

DC output wire shall be UL approved XHHW or RHH/RHW (for Canadian users, RW90 Type). Control and sense wires shall be UL approved Style 1015 (for Canadian users, TEW type).

5.7.1 Circuit Breaker Distribution

The shelf is factory-equipped with four AM-style bullet-type breakers.

NOTE: *Battery breakers should be series-trip to ensure effective alarm operation; service personnel must reset the breaker to clear the alarm.*

NOTE: *When there is no power on the rectifiers and there is only one battery circuit breaker, there will be no alarm if the circuit breaker trips.*

Secure the positive and negative cable leads to the shelf output terminal blocks of the correct polarity; i.e., +V_{cab} to +V_{post}.

The common output leg of the rectifier system should be connected to ground. This is typically done at the load common termination point (negative bus bar for +12V systems).

Refer to schematic drawing 030-770-05 with respect to the output terminal block configurations as follows:

- For List 80, battery outputs 5 and 6 and load outputs 1 – 4 are connected.
- For List 84, battery outputs 5 and 6 and load outputs 1 – 2 are connected, 3 and 4 are not.

Replace rear cover once all connections have been completed.

5.8 CAN Out Port

A single CAN Out port, for communications with CAN-enabled equipment (nodes), is located on the shelf backplane.

Daisy-chain from node to node (CAN OUT of one node to CAN IN of another) as necessary and ensure that only the last node is terminated.

5.9 Network Connection and Remote Communications via CXCI

The Cordex system can be set up, monitored and tested via modem or ETHERNET 10/100 Base-T serial data connection. The communication protocol supports a web interface. Some standard scenarios are described below:

5.9.1 Modem Port (Straight Through Cable)

The Modem port is designed for CXCI connection to a user supplied modem via a front panel DB-9 connector. Connect to the CXCI from the modem with a straight through cable.

5.9.2 Ethernet Port for Network Connection (Standard Network Cable)

The Ethernet port is designed for CXCI connection to a user supplied network (TCP/IP secured by user) via a front panel RJ-45 jack.

Connect to the CXCI using a standard network cable. Pinouts are shown in drawing 030-770-08.

5.9.3 Ethernet Port for Local Connection (Crossover Cable)

Local access (e.g. laptop computer) is also possible from the Ethernet port connection using a standard network crossover cable.

5.10 Signal Wiring Connections

For terminal block connections, the recommended wire sizes are 0.129 to 0.823mm² (#26 to #18AWG) for the temperature range of 0 to 50 deg. C (as per UL/CSA).



CAUTION: to reduce risk of fire, use only 0.129mm² (#26 AWG) or larger wire.

Terminal	Description	Default Name	Signal Type	Range
1, 2, 3*	LVD Control (internal)	K1, Relay 1	NO/COM/NC	60VDC / 1A
4, 5, 6*	Alarm Output 2	K2, Relay 2	NO/COM/NC	60VDC / 1A
7, 8, 9*	Alarm Output 3	K3, Relay 3	NO/COM/NC	60VDC / 1A
10, 11, 12*	Alarm Output 4	K4, Relay 4	NO/COM/NC	60VDC / 1A
13, 14**	Digital Input 1 (internal)	D1, Digital 1	Pos (+) or Neg (-)	0—60VDC
15, 16**	Digital Input 2	D2, Digital 2	Pos (+) or Neg (-)	0—60VDC
17, 18***	Voltage Input 1	V1, Load Voltage	Pos (+) / Neg (-)	0—60VDC
19, 20***	Temp Probe 1	T1, Analog Input T1	Pos (+) / Neg (-)	0—20VDC
21, 22***	Temp Probe 2	T2, Analog Input T2	Pos (+) / Neg (-)	0—20VDC
23	Battery +12V	Batt Hot	Neg (-)	20—60VDC
24, 25	Current Input 1 (internal)	I1, Load Current	Pos (+) / Neg (-)	±50mV

Table B—Wiring connections for CXCI

* NO and NC Form C contacts available. Can be configured to de-energize on alarm (DOA) or energize on alarm (EOA).

** See Table C for definitions of logic and system.

*** Voltage (Input) is 0—60VDC, Temp Probe is 0—20VDC with power source.

NOTE: To aid the user with installation, frequent reference is made to drawings located at the rear of this manual. Custom configurations may be detailed within the Argus power system documentation package.

The input cables should be bundled together and routed through the entry holes of the shelf, if applicable.

5.10.1 Analog Inputs for CXCI

CAUTION: Ensure the correct polarity is used for all input cable terminations.

The analog input channels are used to monitor various types of electrical signals.

5.10.1.1 Voltage

Voltage Input #1 (load voltage per CXC software) terminals on the shelf (V1 on TB12) provide connections to an optional secondary voltage input. For example, this can be terminated to the load side of an LVD contactor to monitor load voltage.

Voltage Input #2 (battery voltage per CXC software) is wired internally to the rectifier output voltage of the shelf. This is used as the reference for system alarming (such as high voltage) and control (such as LVD).

The Battery +12V should be connected at the battery system voltage terminal for CXCI reference when a battery disconnect device is used. It is critical to CXCI operation as it ensures a source of power to the CXCI should the disconnect device open the circuit.

For List 87, the Battery +12V is factory wired for internal battery disconnect.

5.10.1.2 Temperature Sensor

Temperature Probe input channels (T1 and T2 on TB12) provide connections for up to two temperature sensors. A voltage is supplied to these terminals for sensor measurements.

5.10.1.3 Current

Current Input #1 (load current per CXC software) is wired internally to the system current shunt (100A/50mV).

5.10.2 Digital Inputs for CXCI

The digital input channels (factory-installed) are used to monitor various alarm and control signals. All input channels are voltage activated and accept a bipolar (i.e. negative or positive) DC signal directly.

D1 is wired internally for CB/fuse trip. D2 on TB12 is available for customer connections as required.

5.10.2.1 Connection Method

Typical Argus systems use the “reset with Hot and trigger with Ground” connection. The digital input is wired in such a way that the Hot is wired directly into one of the input terminals; e.g., positive input for +12V systems. The other input terminal is wired to the Ground (common) of the system through a relay (dry contact – usually located on the equipment requiring monitoring). This method (see Figure 4) allows the digital input to receive (or not receive) a Ground signal on an alarm.

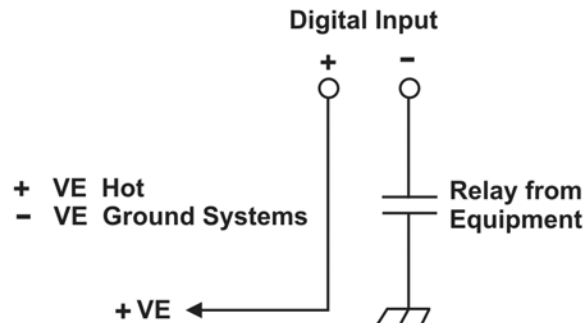

Figure 4—Showing digital input connection method

5.10.2.2 Programming the Digital Input

The digital input channels can be programmed for “active high” or “active low.” Active high indicates “alarm on the presence of a ground signal” and active low indicates “alarm on the removal of a ground signal.” See CXC Software manual for detailed instruction on programming.

Voltage Range (VDC)	Voltage Level (VDC) Considered As “0” (Off)	Voltage Level (VDC) Considered As “1” (On)
0—60 (system voltage setting)	0—3	9—60

Table C—Voltage level definitions for digital inputs

5.10.3 Alarm (Relay) Outputs

Terminals provide contacts for extending various alarm or control signals. Each relay output can be wired for NO or NC operation during an alarm or control condition. See Figure 5.

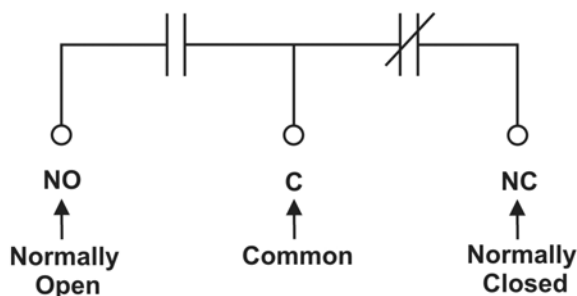

Figure 5—Showing relay connections

Relays can be programmed to energize or de-energize during an alarm condition (see CXC Software manual). When the CXCI reset button is pressed or power is lost, all relays de-energize.

These relays could be used for additional external LVD contactor control.

5.10.4 LVD Control (Load Disconnect or Battery Disconnect) Option

The disconnect option is controlled by and connected internally to relay K1.

5.10.4.1 LVD Inhibit

Should it be necessary to remove the customer connection board or CXCI, the customer connection board (on the back of the shelf) provides shorting pins (JP2) to inhibit (or override) the LVD Control function.

See drawing 030-770-08 next to TB11-1 (pin1) of the customer connections. If the LVD is controlled on NC contacts (factory default for LVD option), then JP2 pins 1 and 2 must be shorted together to maintain LVD operation. If the LVD is controlled on NO contacts, then JP2 pins 2 and 3 must be shorted together.

5.10.5 LVD Control Alternative

The LVD Control functions can be hardwired directly from an alarm output relay to an external LVD contactor (or panel). See Controls Menu Defaults in the CXC Software manual.

6 Operation

6.1 Main Rectifier States

Rectifier operation can be broken up into five main states:

1. Off,
2. Start delay,
3. Soft start,
4. Normal operation,
5. Turning off.

Each state is characterized as being distinct and necessary for the operation of the rectifier. These states are briefly described below.

6.1.1 Off State

The rectifier will be in the Off state immediately after power is applied to the rectifier or after a rectifier shutdown. The shutdown source may be remote or local shutdown, AC shutdown, OVP or thermal shutdown.

When the rectifier is in this state the DC-DC converter is turned off and the CXC will be monitoring its inputs for the proper conditions to begin the start up sequence.

When the conditions have been met for the rectifier to start up, it will transition to the Start Delay state.

6.1.2 Start Delay State

When the rectifier is in the Start Delay state, the DC-DC converter is held off and still not sourcing power and is waiting for a given amount of time before transitioning to the next state.

When in this state, the CXC continues to monitor its inputs.

After the Start Delay state the rectifier will transition to the Soft Start state.

NOTE: *Soft start, or current walk-in, gradually increases the voltage and current output of the rectifier upon startup. This is done to reduce the instantaneous load on the AC source.*

6.1.3 Soft Start State

When the Soft Start state is entered, the rectifier will be turned on and the output voltage and output current will be gradually increased. If a load is present, the rectifier will begin to source power.

When the voltage and current limit ramps have finished, the rectifier will transition to the Normal Operation state.

6.1.4 Normal Operation State

The Normal Operation state is the state that the rectifier will be in performing all of the rectifier functions and features specified herein.

From this state, the only valid transition is to the Turning Off state. This transition will happen if the rectifier is required to shut down.

6.1.5 Turning Off State

The Turning Off state is entered because a short delay is required before the rectifier actually turns off to take care of any initialization requirements.

When this short delay has elapsed, a transition to the Off state is made.

6.2 Main Rectifier Modes

In addition to Main Rectifier States, there is a set of Main Rectifier Modes. These modes can be divided into two categories as follows:

6.2.1 Output Voltage Modes

Voltage modes can be thought of as modes that, under software control, can directly adjust the output voltage. The qualification of 'under software control' is made because there are processes that occur in the rectifier that can change the output voltage that do not adjust the output voltage directly (such as the rectifier being in current limit).

The following table lists the five Output Voltage Modes and a description of when they are active:

Output Voltage Modes	Active when...
Float	Output voltage is set to the float voltage setting.
Equalize	Output voltage is set to the equalize voltage setting.
Battery Test	Output voltage is set to the battery test voltage setting.
Safe	Output voltage is set to the safe mode voltage setting.
Manual Test	Output voltage can be manually adjusted outside of the standard adjustment ranges.

Table D–Output voltage modes

6.2.2 Output Current/Power Modes

These modes directly affect the output current and power.

The following table lists the four Output Current/Power Modes and a description of when they are active:

Output Current/Power Mode	Active when...
Temperature foldback mode	Output current and power limit have been reduced due to high temperature of the heatsink or internal ambient temperature sensor.
AC foldback mode	Output current and power limit have been reduced due to low AC input voltage. <i>Note: this will reduce the risk of tripping an AC breaker due to increased AC current draw as the AC voltage decreases.</i>
Short circuit foldback mode	Output current limit has been reduced due to a short circuit at the output.
Internal fault foldback mode	Output current limit has been reduced due to an internal fault.

Table E–Output current/power modes

6.3 Can Bus Communications

The CAN bus is used for communication between the rectifier and CXC.

The communication between the rectifier and CXC consists of commands and data transfer that are used during the operation of the power system to configure the rectifier with system settings and to monitor rectifier status.

6.4 Factory Ranges and Defaults

The following table lists the rectifier settings/ranges/defaults; changes are made via the CXC:

Setting	Range (minimum to maximum)	Default
Float (FL) Voltage	11.88 – 14.50V	13.50V
Equalize (EQ) Voltage	12.45 – 14.50V	13.75V
Battery Test (BT) Voltage	11.00 – 13.00V	11.50V
OVP	See note below – 15.00V	14.25V
Current Limit (CL)	20 – 100%	100%
Power Limit (PL)	0 – 100%	100%
Module Start Delay	0 – 250s	1s
System Start Delay	0 – 600s	0s
Low Voltage Alarm (LVA)	10.50 – 13.00V	11.00V
High Voltage Alarm (HVA)	13.00 – 15.00V	14.00V
EQ Timeout	1 – 2399h	30h
BT Timeout	1 – 250h	8h
Softstart Ramp-rate	Normal/Fast	Normal
CL/PL Alarm	Enable/Disable	Enable
Remote Shutdown	Enable/Disable	Enable
Ramp Test	Enable/Disable	Enable

Table F–Cordex 12-250W factory ranges and defaults

NOTE: OVP cannot be set below the present system/FL/EQ/BT voltage setting or the safe mode voltage of 12.85V.

7 System Startup

After completing the shelf wiring and installation, perform the following startup and test procedure to ensure proper operation:

7.1 Check System Connections

- Ensure AC is off, battery is disconnected, and all power modules are removed from the shelf.
- Triple check the polarity of all connections.

7.2 Verify AC and Power the Shelf

- Install one power module.
- Verify AC input voltage is correct and turn on the corresponding AC input feeder breaker.
- The power module OK LED should illuminate after a preset start delay.
- Using the CXCI, test functionality of various module alarms and controls.

7.3 Check Battery Polarity and Connect

- Verify correct battery polarity using a voltmeter (ensuring no cells or batteries are reversed).
- Connect battery as required to the output of the system or turn on battery breaker.
- Install remaining power modules.
- In the adjustments menu of the CXCI (web browser), set Float and Equalize voltage to the levels specified by the battery manufacturer.
- Using the CXCI, test functionality of various module alarms and controls. In addition, perform a load test with the system using a resistive load box as needed.

7.4 CXC Reset

7.4.1 Soft Reset

The reset button located on the front panel of the CXCI is for restarting the microprocessor. When pressed momentarily, the unit beeps twice then resets. The front-panel LED's will illuminate temporarily, but will extinguish after the system has finished its 15-second self-test.

7.4.2 IP Address Reset

To reset the IP address, press and hold the front panel reset button for three seconds. The CXCI unit will beep three times, IP will be reset (to 10.10.10.201) and DHCP will be disabled. The settings will be saved and the unit will then reset.

This will allow local access; e.g., with a laptop and a standard network crossover cable. See current version software manual for details.

7.4.3 Hard Reset

There is a second reset button located to the right of the front panel on the side of the CXCI. This may be used to restart the microprocessor in the event that the front panel (soft) reset button fails to operate as described above.

CAUTION: Use of hard reset may cause loss of data.

To access the hard reset button, remove the rectifier module adjacent to the CXCI.

7.4.4 Time Settings

The CXCI, upon startup*, will set the time based on the following:

- Attempt to synchronize with the NTP server (see www.NTP.org).
- Retrieve the last time stamp from the Event Log.
- Retrieve the last time stamp from the Statistics Log.
- Set the time to 2005-01-01 midnight.

* Whenever the unit is reset or power is completely removed from the CXCI.

8 Maintenance

Although very little maintenance is required with Argus systems, routine checks and adjustments are recommended to ensure optimum system performance. Qualified service personnel should do repairs.

The following table lists a few maintenance procedures for this system. These procedures should be performed at least once a year.

WARNING: HIGH VOLTAGE AND SHOCK HAZARD.



Use extreme care when working inside the shelf while the system is energized. Do not make contact with live components or parts.

Circuit cards, including RAM chips, can be damaged by static electricity. Always wear a grounded wrist strap when handling or installing circuit cards.

Procedure	Date Completed
Clean ventilation openings	
Inspect all system connections (re-torque as necessary)	
Verify alarm/control settings	
Verify alarm relay operation	

Table G—Sample maintenance log

8.1 CXCI Replacement Procedure

1. Write down the CXCI communication information: dynamic or static IP, IP address, and gateway.
2. Connect user laptop to CXCI per software manual; standard network crossover cable to Ethernet port.
3. A step-by-step connection (wizard) application – provided to establish remote communications with your CXCI – is available via the Argus website (www.argusdcpower.com). The CXCI Connection Wizard will save your LAN configuration and restore it back when exiting the application.
4. Save CXCI configuration file (see software manual).
5. Bypass system LVD as required; short the pins at JP2 (connections on the back of CXCI system shelf shown in Figure 6) to inhibit (or override) the LVD Control function. If the LVD is controlled on NC contacts (factory default for LVD option), then JP2 pins 1 and 2 must be shorted together to maintain LVD operation. If the LVD is controlled on NO contacts, then JP2 pins 2 and 3 must be shorted together.

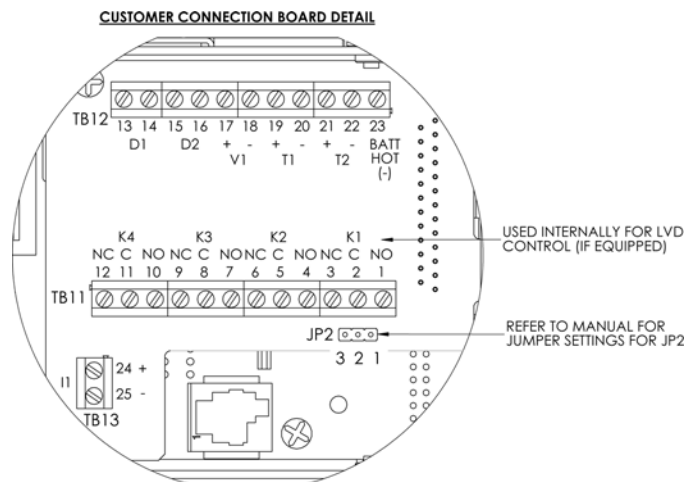

Figure 6—Showing location of LVD bypass jumper

Unit Description: CORDEX INTEGRATED SHELF WITH CXCI

Date: 2007-10-10

Documents Affected P/N: 030-728-C0, 030-752-C0, 030-763-C0, 030-773-C0, 030-776-C0, 030-781-C0, 030-782-C0, 030-783-C0, 030-820-C0

Correction to be implemented: Insert section below (replaces document 70742020d2_addendum_CXCI.doc).

CXCI Replacement Procedure



1. Refer to all safety instructions provided in the documentation package provided with your system.

WARNING: HIGH VOLTAGE AND SHOCK HAZARD.

Use extreme care when working inside the enclosure/shelf while the system is energized. Do not make contact with live components or parts.

Circuit cards, including RAM chips, can be damaged by static electricity. Always wear a grounded wrist strap when handling or installing circuit cards.

2. Write down the CXCI communication information: dynamic or static IP, IP address, and gateway.
3. Connect user laptop to CXCI per software manual; standard network crossover cable to Ethernet port.
4. A step-by-step connection (wizard) application – provided to establish remote communications with your CXC – is available via the Argus website (www.argusdcpower.com). The CXC Connection Wizard will save your LAN configuration and restore it back when exiting the application.
5. Save CXCI configuration file (see software manual).
6. Bypass system LVD as required; short the pins at JP2 (connections on the back of CXCI system shelf shown below) to inhibit (or override) the LVD Control function. If the LVD is controlled on NC contacts (factory default for LVD option), then JP2 pins 1 and 2 must be shorted together to maintain LVD operation. If the LVD is controlled on NO contacts, then JP2 pins 2 and 3 must be shorted together.
7. Ensure rectifier is in the right-most position. Remove rectifier in the left-most position in order to access the side of the CXCI where the mounting screws are located.
8. Remove three mounting screws from the CXCI as shown below.
9. For CXCI removal/installation, two persons will be required for early revision CXCI I/O PCB (rev B or older). One person, at the back of the system shelf, should grip the terminal blocks on the PCB to prevent it from flexing as the other person, at the front of the CXCI, carefully pulls the controller module clear of the backplane/DB-25 connectors.
10. Install the new CXCI: one person must apply minimal pressure to the I/O PCB terminal blocks while the other person pushes the CXCI into the connectors. The front panel should not be removed and is used to grip (with thumb and index finger) along bottom and top edge for removal/insertion. CAUTION - Do not push on the LCD.
11. Reinstall the three mounting screws.
12. Review steps 2 through 4 with respect to new installation and upload the saved CXCI configuration file to the new controller.
13. Use a meter to verify the buss voltage and current shunt. Recalibrate as required due to differences in the new CXCI.
14. Replace rectifiers and remove LVD bypass.

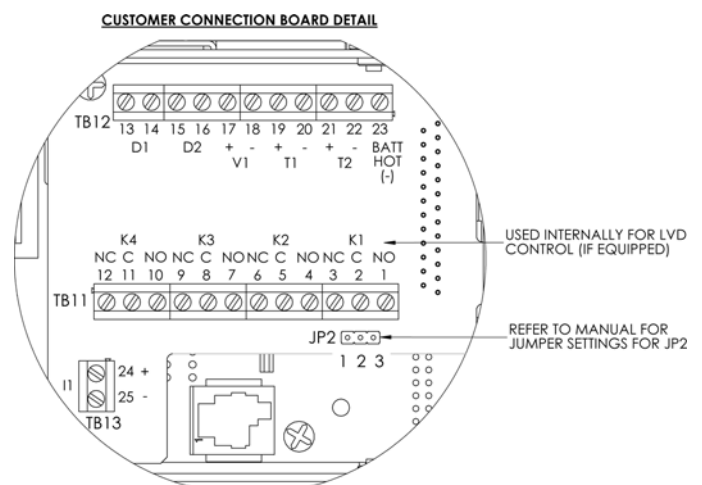
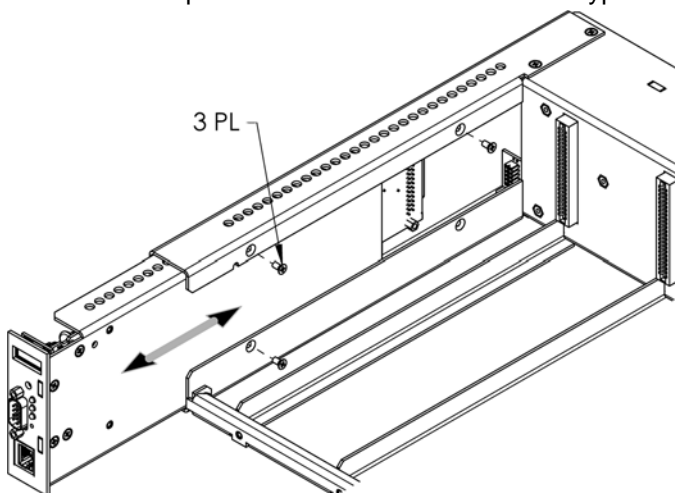

9 Argus Conventions

9.1 Numbering System

Argus Technologies uses an eight-digit drawing number system, which is broken into three blocks. The first three digits describe the category of the product; e.g., rectifier or fuse panel. The next three digits indicate the sequence in which the product number was allocated in a particular category. The last two digits indicate the type of drawing, for example:

“-06”	Outline Drawing
“-08”	Customer Connections
“-20”	Main Assembly

Argus uses an eight-digit part numbering system for all components and sub assemblies. Each part is covered by its own unique number. Due to the quantity, categories will not be listed within this manual.

9.2 Acronyms and Definitions

AC	Alternating current
ANSI	American National Standards Institute
AWG	American wire gauge
BTU	British thermal unit
CAN	Controller area network
CEC	Canadian Electrical Code
CSA	Canadian Standards Association
CX	Cordex™ series; e.g., CXC for <u>C</u> ordex <u>S</u> ystem <u>C</u> ontroller
DC	Direct current
DHCP	Dynamic host configuration protocol
EIA	Electronic Industries Alliance
EMC	Electromagnetic compatibility
EMI	Electromagnetic interference
ERM	<u>E</u> lectromagnetic compatibility and <u>r</u> adio spectrum <u>m</u> atters
ESD	<u>E</u> lectrostatic <u>d</u> ischarge
FCC	Federal Communications Commission (for the USA)
HVSD	<u>H</u> igh <u>v</u> oltage <u>s</u> hutdown
IEC	International Electrotechnical Commission
IEEE	Institute of Electrical and Electronics Engineers
IP	Internet protocol
LED	Light emitting diode
LVD	Low voltage disconnect
MTBF	Mean time between failures
NC	Normally closed
NEC	National Electrical Code (for the USA)
NO	Normally open
OSHA	Occupational Safety & Health Administration
OVP	Over voltage protection
RAM	Random access memory
RU	Rack unit (1.75”)
TCP/IP	Transmission control protocol / internet protocol
THD	Total harmonic distortion
UL	Underwriters Laboratories

REVISION			
LTR	DESCRIPTION	DATE	APPD
B	REVISED PER EO A1	08/08	JK
C	LOAD SHUNT CHANGED TO BATTERY SHUNT	07/03	

PCB ASSY, CXCJ, MOTHERBOARD
 PART NUMBER: 707-420-20
 SCHEMATIC: 707-420-05

PCB ASSY, I/O INTERFACE, 19" SHELF 2RU,
 5 MDL, CORDEX CXRC
 PART NUMBER: 707-479-20
 SCHEMATIC: 707-479-05

PCB ASSY, 19" BACKPLANE CXRC 650W
 PART NUMBER: 707-422-20
 SCHEMATIC: 707-422-05

LIST 80: 4 LOAD CB, 2 BATT TERMINATIONS

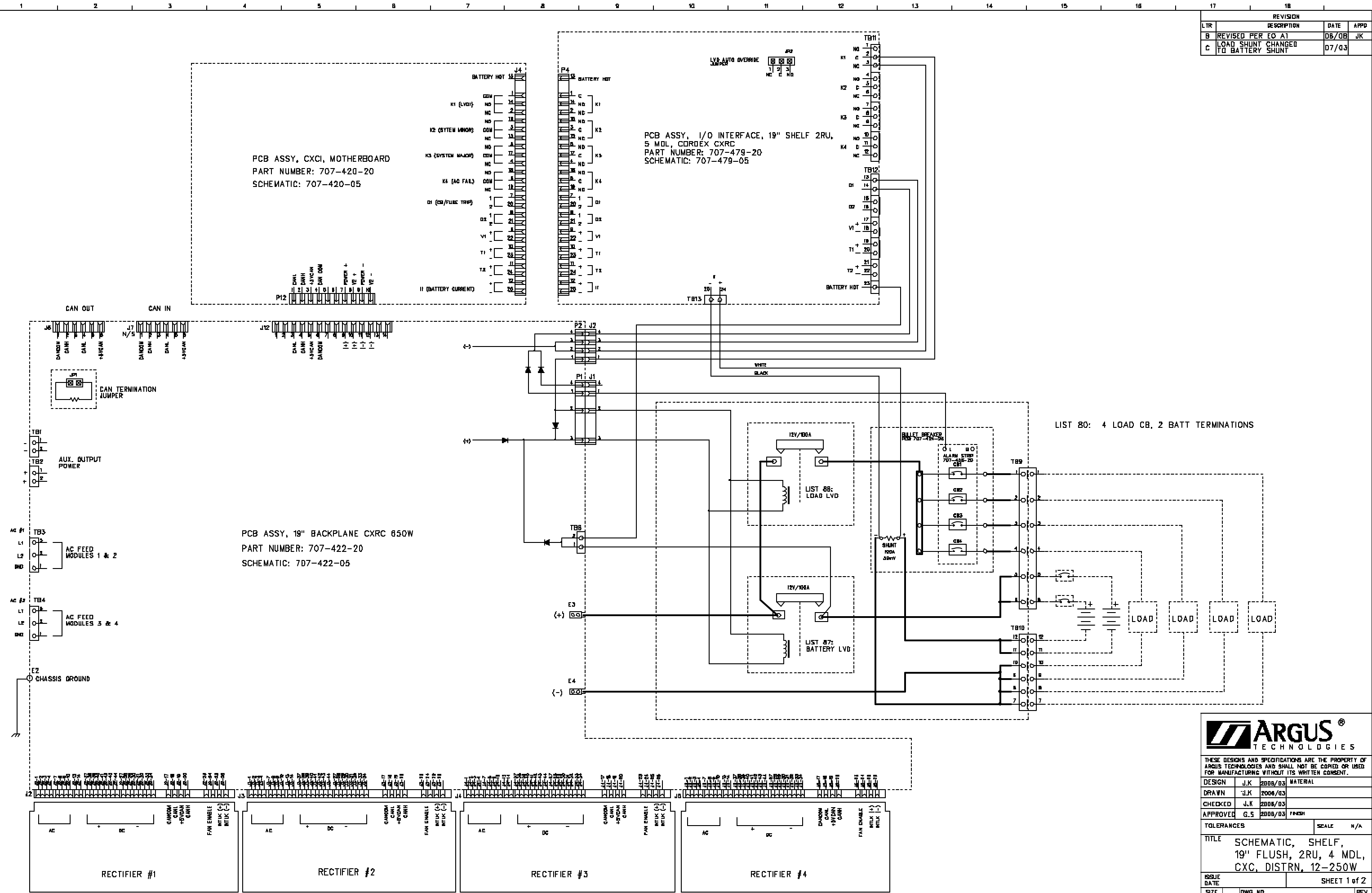

THESE DESIGNS AND SPECIFICATIONS ARE THE PROPERTY OF ARGUS TECHNOLOGIES AND SHALL NOT BE COPIED OR USED FOR MANUFACTURING WITHOUT ITS WRITTEN CONSENT.

DESIGN	JK	2008/03	MATERIAL
DRAWN	JK	2008/03	
CHECKED	JK	2008/03	
APPROVED	G.S	2008/03	FINISH

TOLERANCES SCALE N/A
 TITLE SCHEMATIC, SHELF, 19" FLUSH, 2RU, 4 MDL, CXC, DISTRN, 12-250W

ISSUE DATE	SHEET 1 of 2	
SIZE B	DWG NO. 030-770-05	REV C

REVISION			
LTR	DESCRIPTION	DATE	APPD

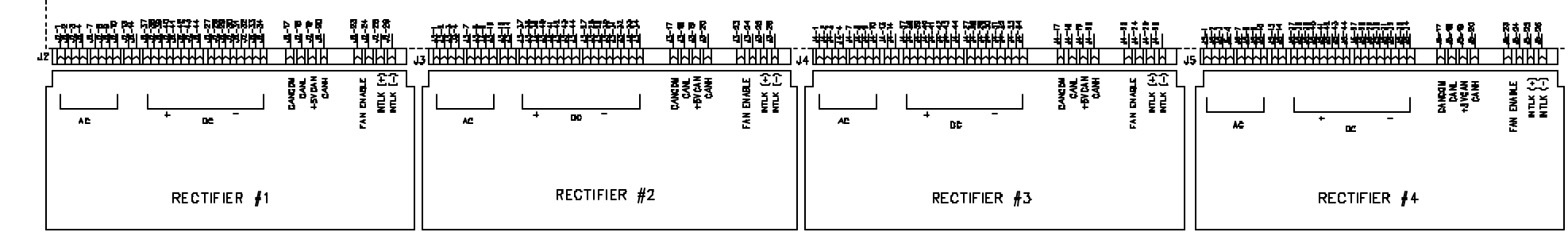
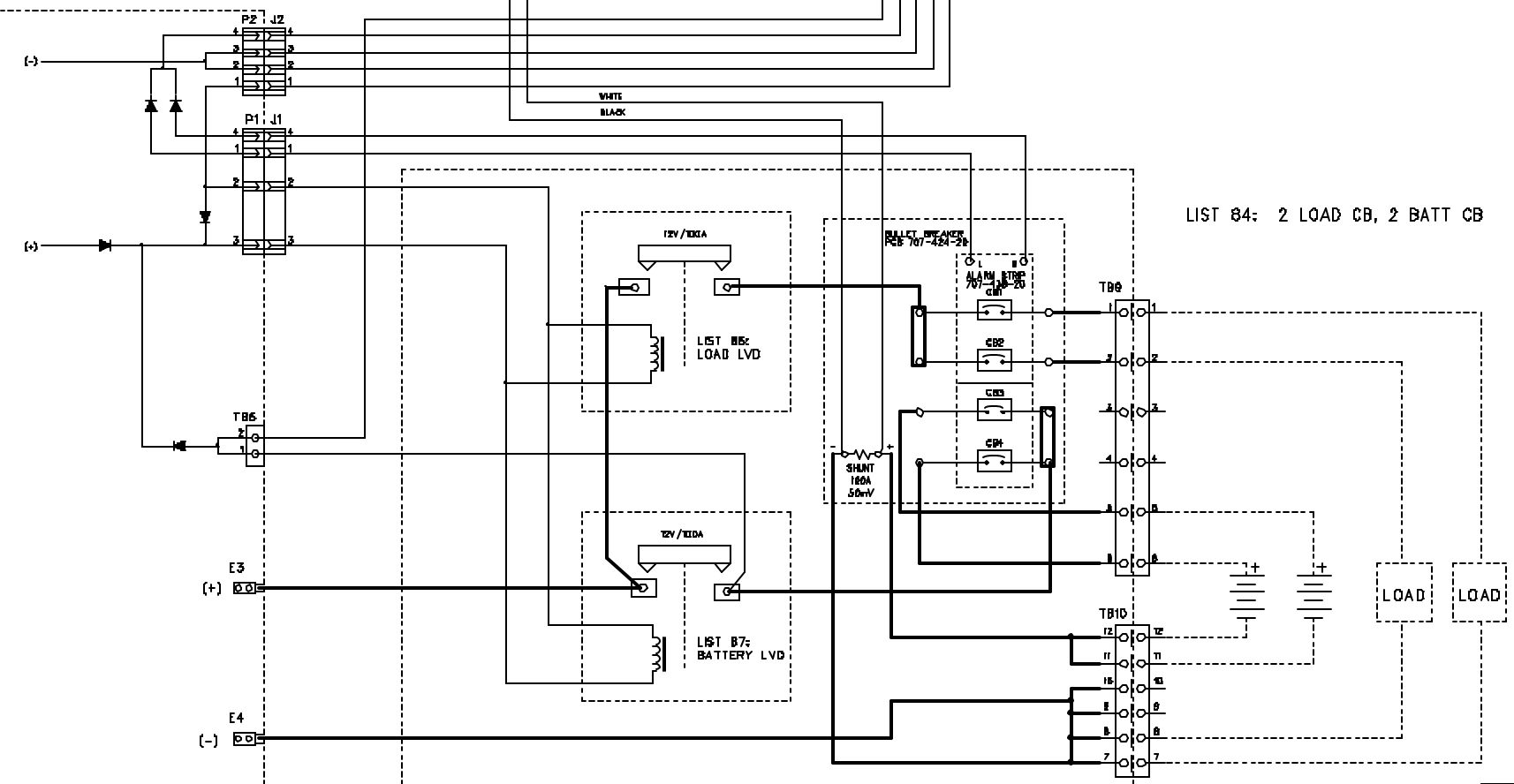
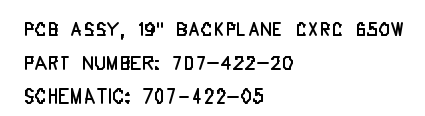
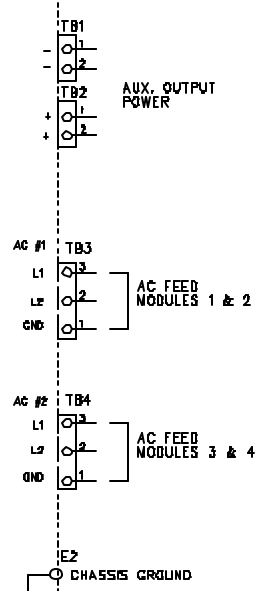
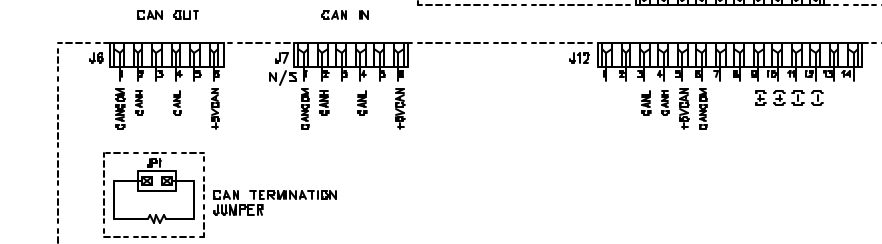
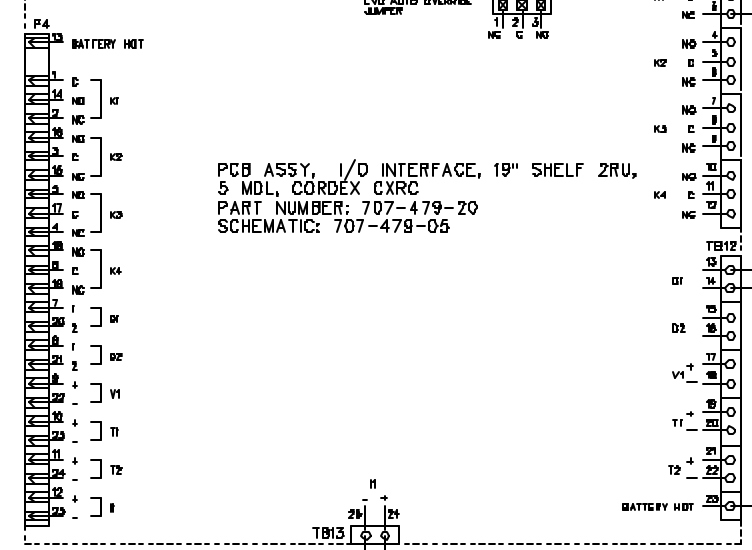
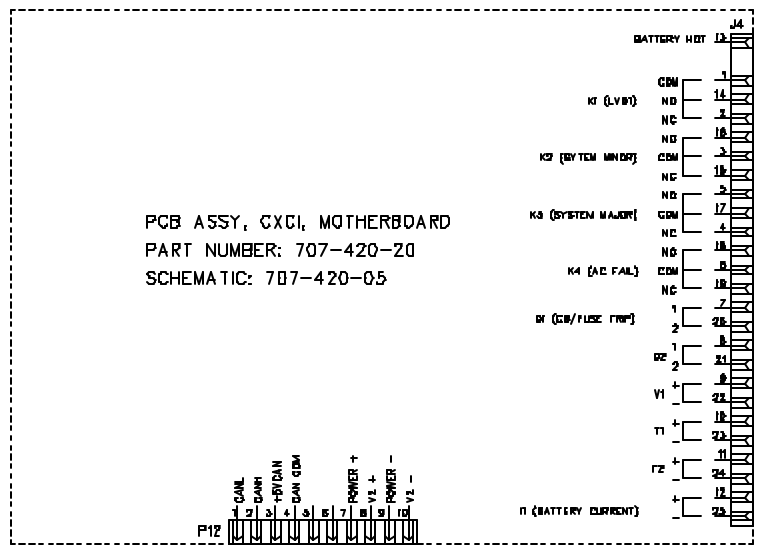

© 2005 ARGUS TECHNOLOGIES

ARGUS

THESE DESIGNS AND SPECIFICATIONS ARE THE PROPERTY OF ARGUS TECHNOLOGIES AND SHALL NOT BE COPIED OR USED FOR MANUFACTURING WITHOUT ITS WRITTEN CONSENT.

DESIGN	J.K	2004/03	MATERIAL
DRAWN	J.K	2004/03	
CHECKED	J.K	2004/03	
APPROVED	G.S	2004/03	F.N.B.H

TOLERANCES SCALE N/A

TITLE SCHEMATIC, SHELF,
19" FLUSH, 2RU, 4 MDL,
CXCI, DISTRN, 12-250W

ISSUE DATE	SHEET 2 of 2
SIZE B S3	DWG NO. 030-770-05
REV C	

REVISIONS				
LTR	DESCRIPTION	REV BY	DATE	APPD
B	REVISED PER EO A1	SDW	2006/08	JK
C	UPDATED CXCI MODULE	SDW	2006/09	

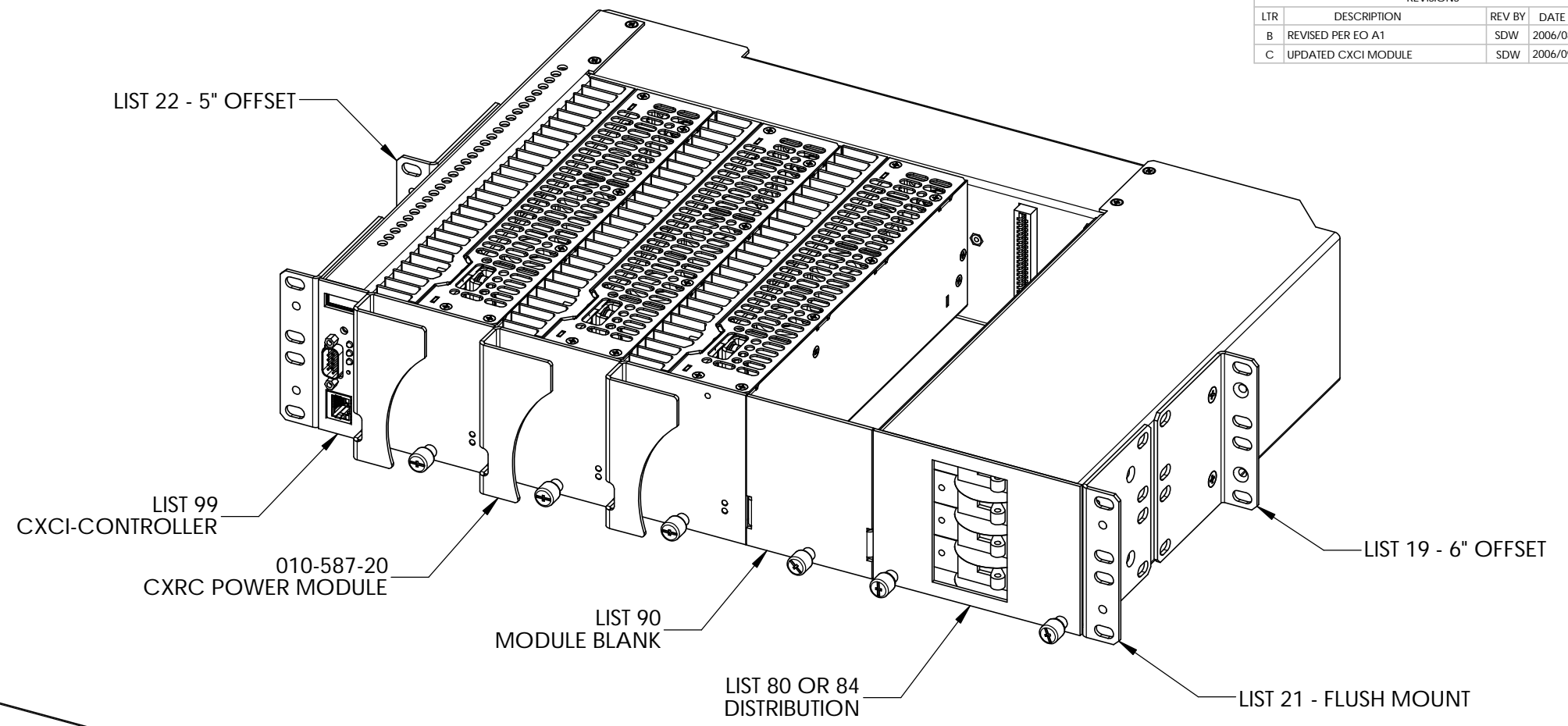

19" RACK MOUNT OPTIONS

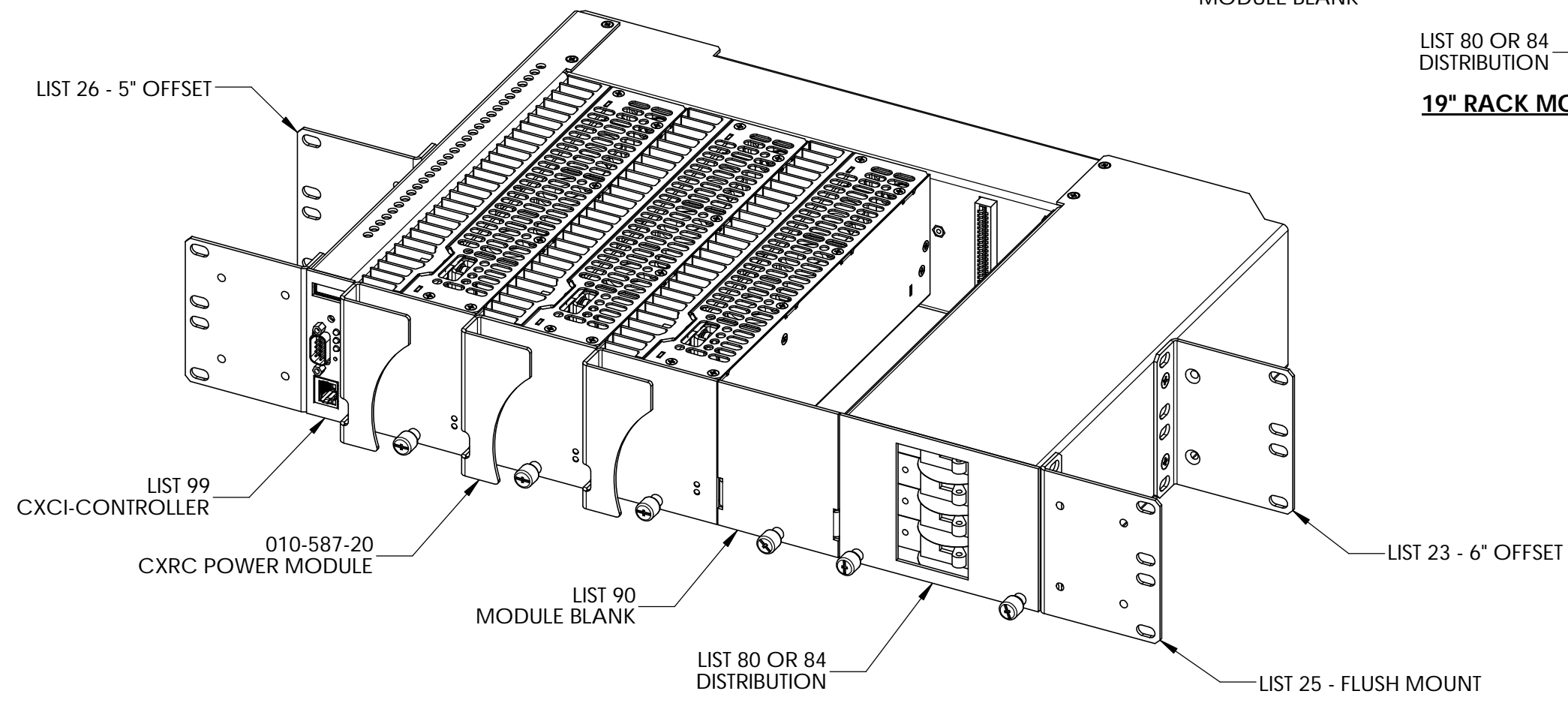

23" RACK MOUNT OPTIONS

ARGUS[®]

THESE DESIGNS AND SPECIFICATIONS ARE THE PROPERTY OF ARGUS TECHNOLOGIES AND SHALL NOT BE COPIED OR USED FOR MANUFACTURING WITHOUT ITS WRITTEN CONSENT.

DESIGN	RP	2006/03	MATERIAL
DRAWN	RP	2006/03	
CHECKED	JK	2006/03	
APPROVED	GS	2006/03	FINISH

TOLERANCES			
X.X	±0.04"	[X]	±1mm
X.XX	±0.02"	[X.X]	±0.5mm
X.XXX	±0.01"	[X.XX]	±0.25mm
			SCALE NTS

TITLE
**OUTLINE, SHELF, 19" FLUSH,
 2RU,4 MDL,CXC,DISTRN,250W**

ISSUE DATE SHEET 1 OF 2

REVISIONS				
LTR	DESCRIPTION	REV BY	DATE	APPD

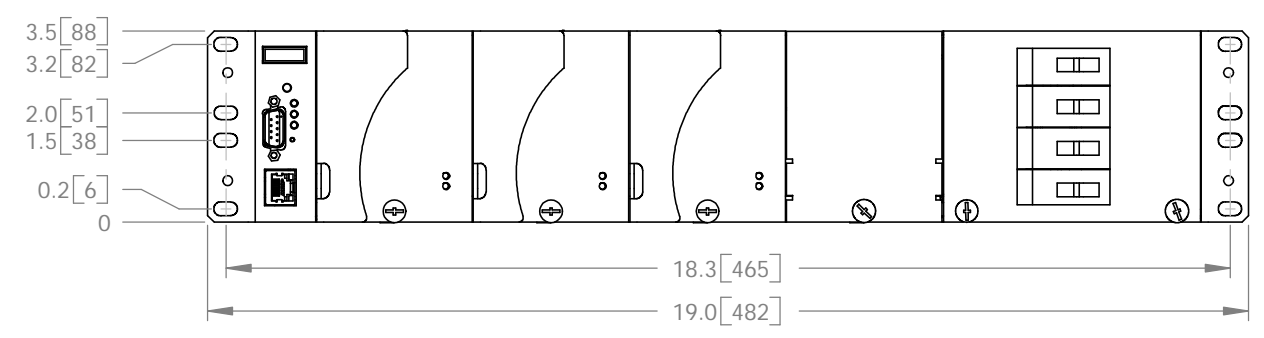
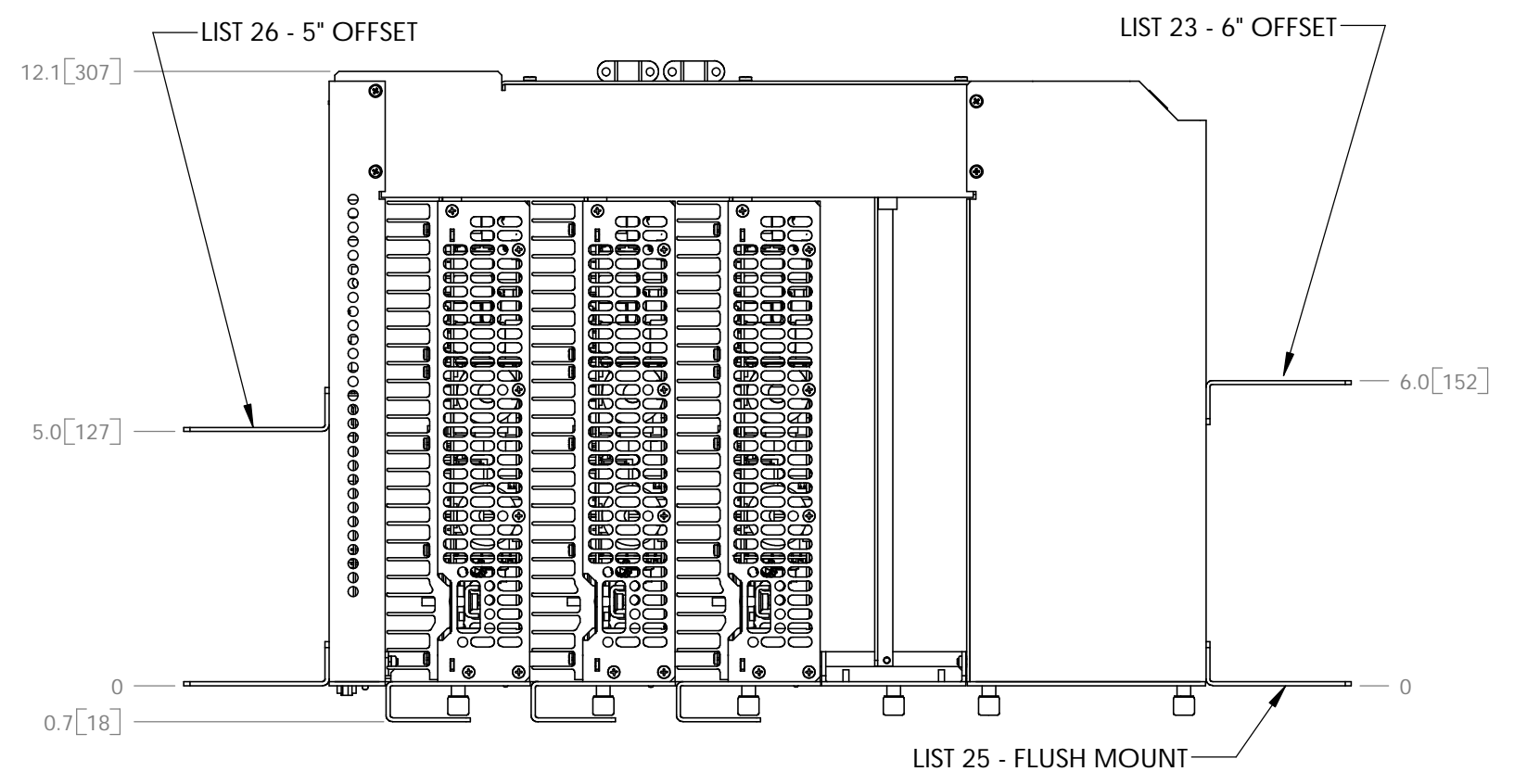
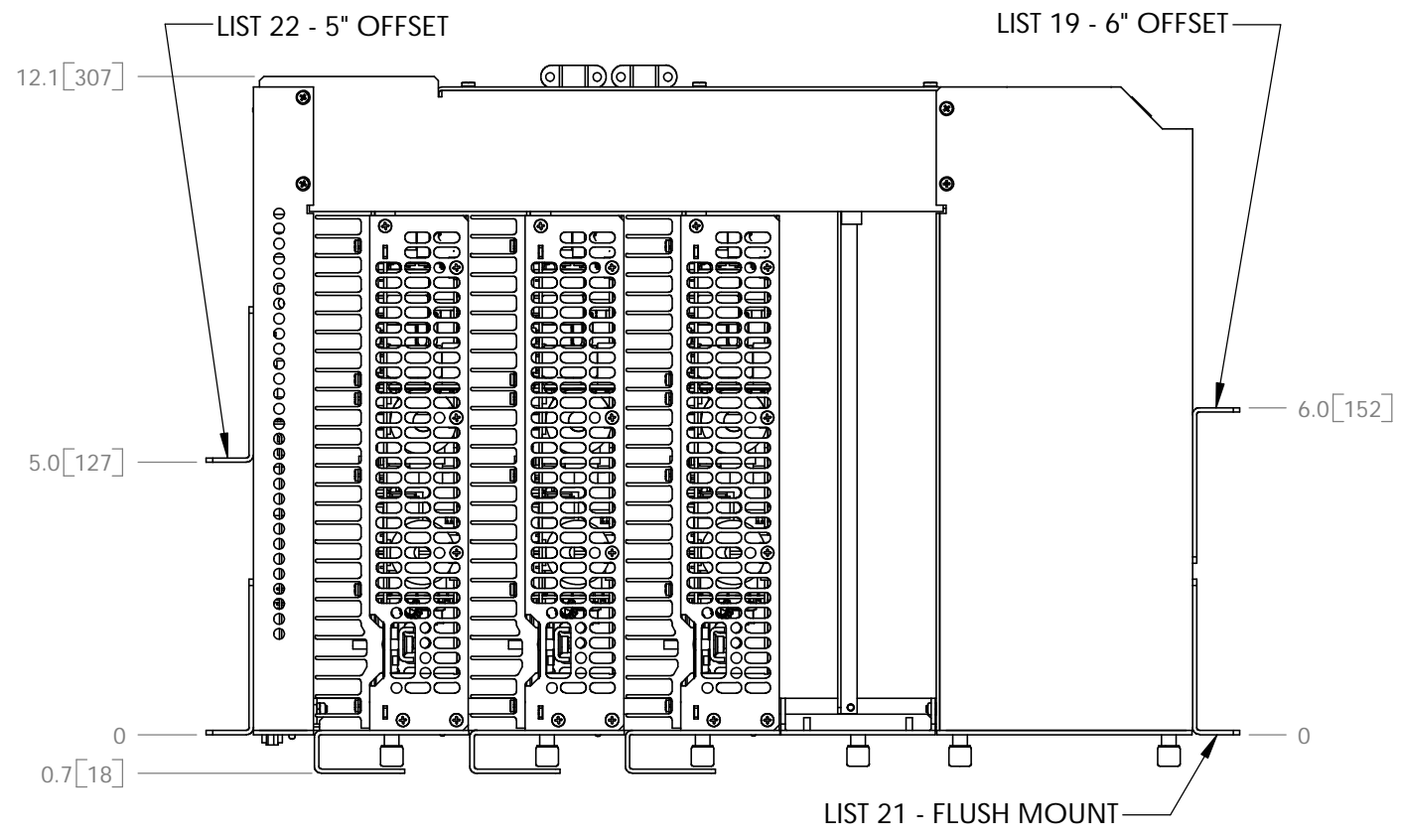

19" RACK OPTION

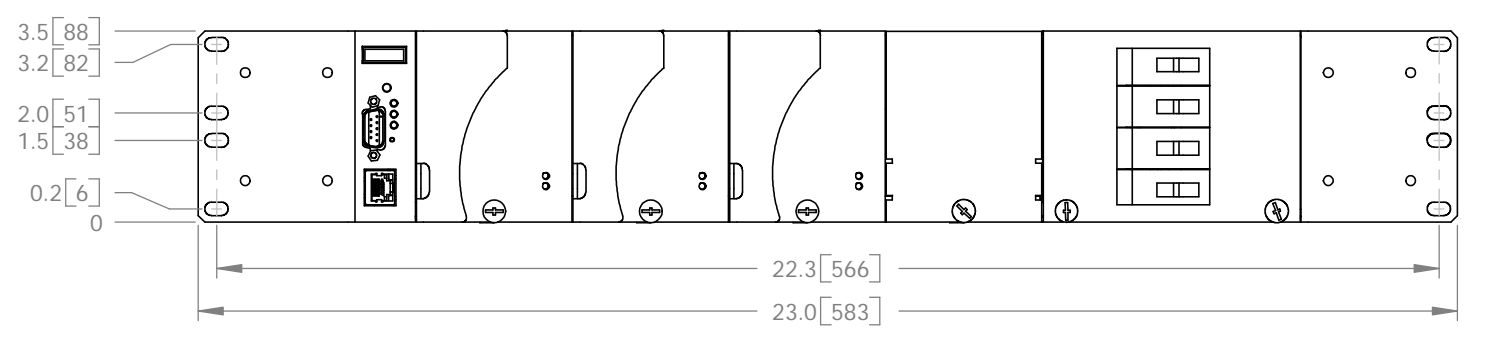

23" RACK OPTION

DIMENSIONS ARE IN INCHES WITH METRIC (mm) IN BRACKETS: INCHES [mm]

© 2006 ARGUS TECHNOLOGIES

ARGUS[®]

THESE DESIGNS AND SPECIFICATIONS ARE THE PROPERTY OF ARGUS TECHNOLOGIES AND SHALL NOT BE COPIED OR USED FOR MANUFACTURING WITHOUT ITS WRITTEN CONSENT.

SCALE NTS

TITLE
OUTLINE, SHELF, 19" FLUSH, 2RU, 4 MDL, CXC, DISTRN, 250W

ISSUE DATE SHEET 2 OF 2

SIZE TYPE DWG NO. REV
 B D2 030-770-06 C

REVISIONS				
LTR	DESCRIPTION	REV BY	DATE	APPD
B	CHANGED SHEET 3 DETAIL VIEW	SDW	2006/08	JK
C	UPDATED CXCI SUPERVISORY	SDW	2006/09	JK
D	CHANGED AC I/P FROM 'L2' TO 'L2/N'	MP	2007/04	JK
E	CORRECTED JP2 PINOUT (SHT.3)	JK	2007/10	

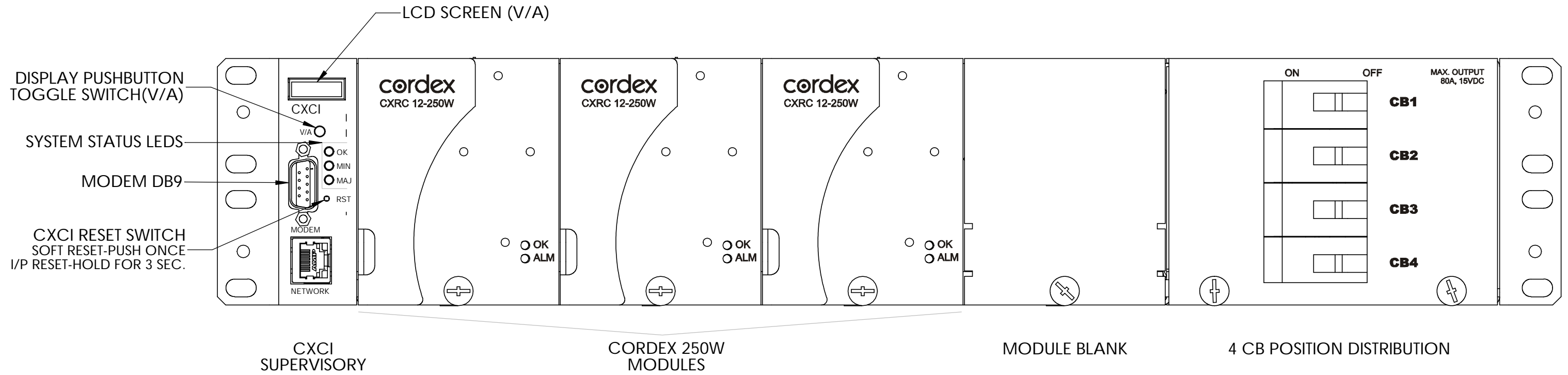

MODEM RS232 DB9

1. DCD
2. RX
3. TX
4. DTR
5. COM
6. DSR
7. RTS
8. CTS
9. RI

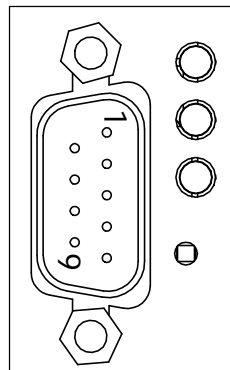

ETHERNET RJ45

1. TX+
2. TX-
3. RX+
4. NOT CONNECTED
5. NOT CONNECTED
6. RX-
7. NOT CONNECTED
8. NOT CONNECTED

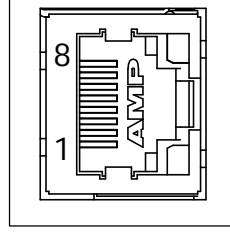

HARD RESET-PUSH ONCE

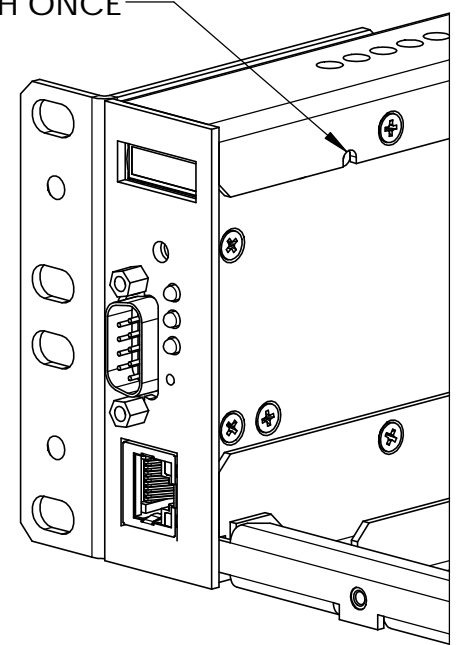

THESE DESIGNS AND SPECIFICATIONS ARE THE PROPERTY OF ARGUS TECHNOLOGIES AND SHALL NOT BE COPIED OR USED FOR MANUFACTURING WITHOUT ITS WRITTEN CONSENT.

DESIGN	RP	2006/03	MATERIAL
DRAWN	RP	2006/03	
CHECKED	JK	2006/03	
APPROVED	GS	2006/03	FINISH

TOLERANCES

X.X	±0.04"	[X]	±1mm
X.XX	±0.02"	[X.X]	±0.5mm
X.XXX	±0.01"	[X.XX]	±0.25mm

SCALE NTS

TITLE
CUSTOMER CONNECTION,
2RU,4 MDL,CXC,DISTRN,250W

ISSUE DATE	SHEET 1 OF 3
SIZE TYPE DWG NO.	REV E

REVISIONS				
LTR	DESCRIPTION	REV BY	DATE	APPD

DC OUTPUT TERMINAL BLOCKS
(MAX. WIRE GAUGE #6 AWG)

TB3 FEEDS MODULES 1 AND 2
TB4 FEEDS MODULES 3 AND 4

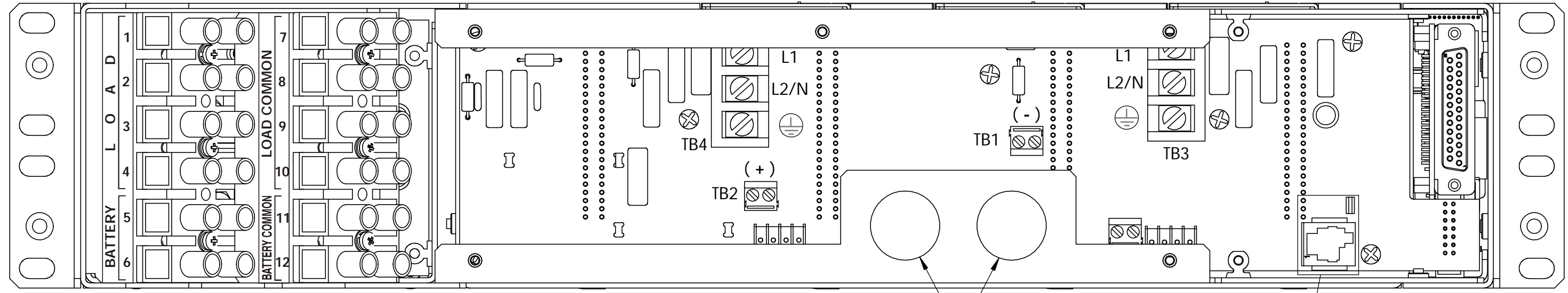

REAR VIEW
(BACK COVER REMOVED)
(CUSTOMER CONNECTION BOARD NOT SHOWN)

AC CABLE ENTRY
Ø0.875"

JUMPER SETTINGS FOR JP1

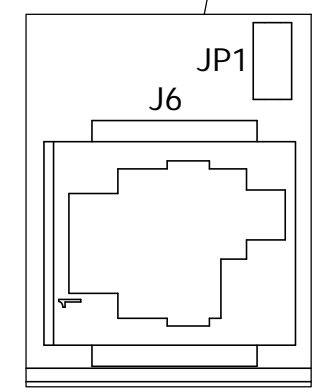
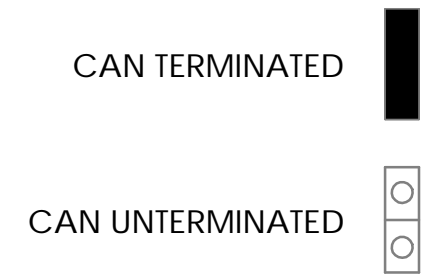

CAN OUT RJ12
PIN OUT (J6)

1. CAN COM
2. CAN H
3. NOT CONNECTED
4. CAN L
5. NOT CONNECTED
6. +5 V CAN

ARGUS[®]

THESE DESIGNS AND SPECIFICATIONS ARE THE PROPERTY OF ARGUS TECHNOLOGIES AND SHALL NOT BE COPIED OR USED FOR MANUFACTURING WITHOUT ITS WRITTEN CONSENT.

SCALE NTS

TITLE
CUSTOMER CONNECTION,
2RU,4 MDL,CXC,DISTRN,250W

ISSUE DATE SHEET 2 OF 3

© 2006 ARGUS TECHNOLOGIES

SIZE TYPE DWG NO. REV
B D2 030-770-08 E

REVISIONS				
LTR	DESCRIPTION	REV BY	DATE	APPD

REAR VIEW
(BACK COVER REMOVED)
(CUSTOMER CONNECTION BOARD SHOWN)

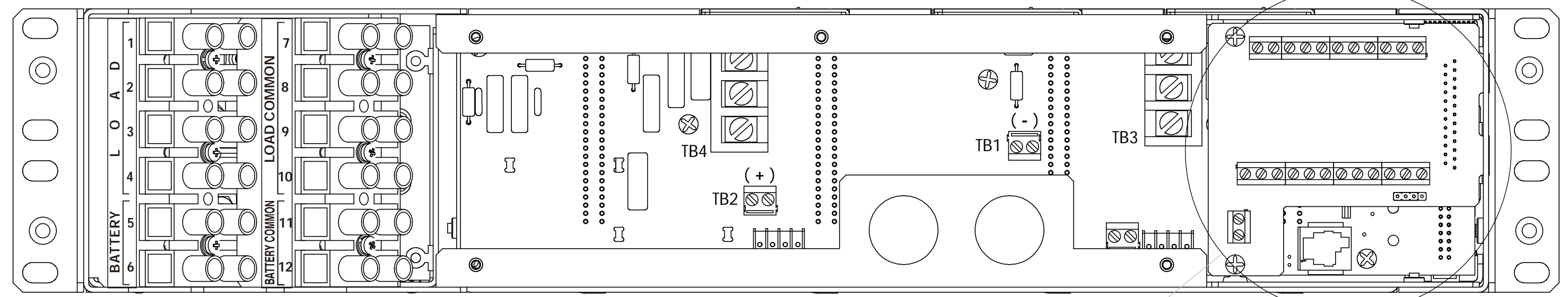

CUSTOMER CONNECTION BOARD DETAIL

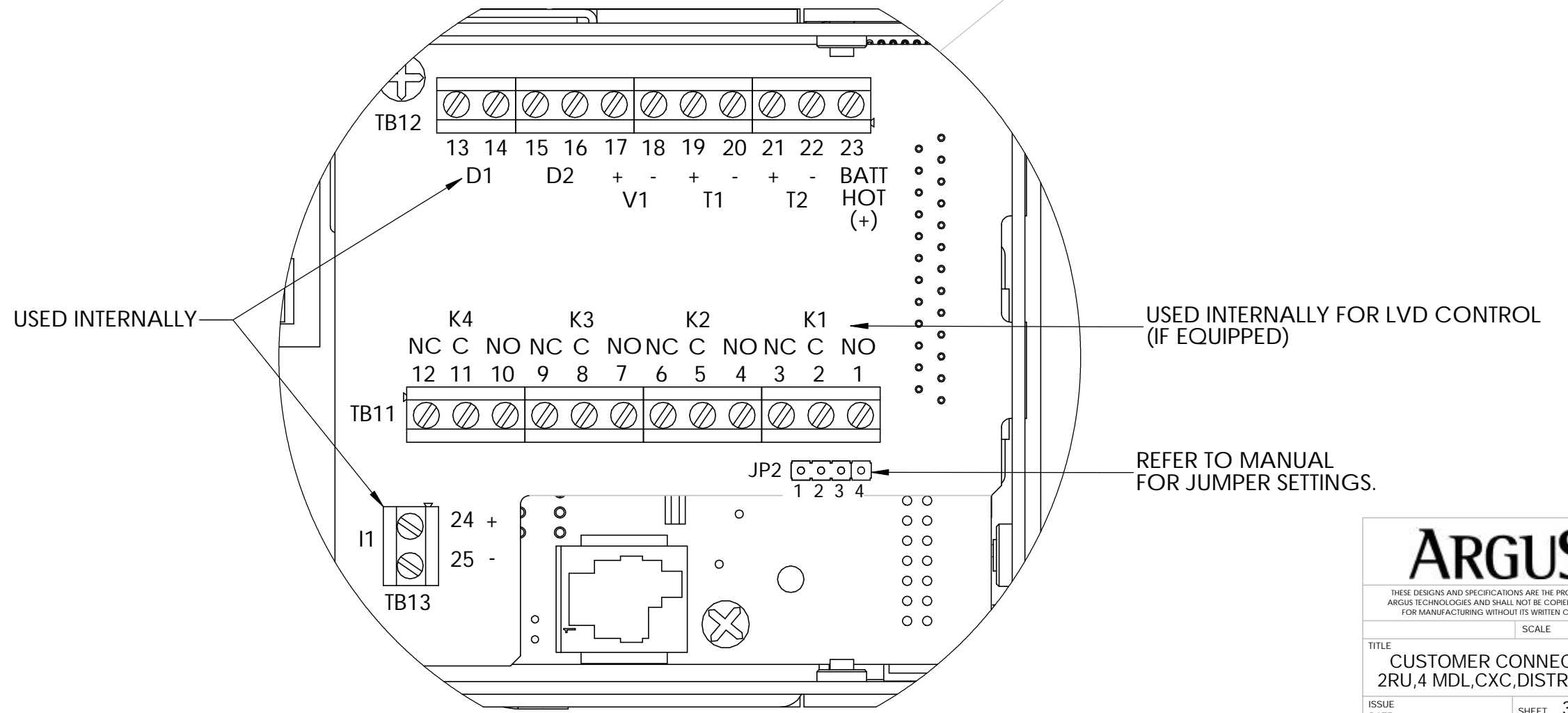

ARGUS[®]

THESE DESIGNS AND SPECIFICATIONS ARE THE PROPERTY OF ARGUS TECHNOLOGIES AND SHALL NOT BE COPIED OR USED FOR MANUFACTURING WITHOUT ITS WRITTEN CONSENT.

SCALE NTS

TITLE
**CUSTOMER CONNECTION,
2RU,4 MDL,CXC,DISTRN,250W**

ISSUE DATE SHEET 3 OF 3

© 2006 ARGUS TECHNOLOGIES

SIZE TYPE DWG NO. REV
B D2 030-770-08 E

FACTORY SERVICE INFORMATION

Technical Support

Technical support staff are available for answering general questions related to installation, operation and maintenance of Argus products. In Canada and the USA, call Argus toll free 7:30 am to 5:00 pm Pacific Standard Time at:

+1-888 GO ARGUS

(+1-888-462-7487)

For emergencies, call +1-888-GO-ARGUS 24 hours a day, seven days a week.
Customers outside Canada and the USA, call +1-604-436-5547 for technical support.

Training

Argus offers various levels of product and technical training. These workshops provide a mix of theory and hands on application for qualified customers. Please consult your sales representative for course schedules, locations and costs, or visit our website at www.argusdcpower.com.

Factory Repair and Servicing

All service, beyond initial adjustments, should be carried out by qualified factory service personnel. For these procedures, please contact Argus Technologies at the locations listed to the right.

Product Returns

Before returning any product for service, please obtain a Return Material Authorization (RMA) number from an Argus factory service representative. The representative will require the model and serial number, as well as a brief description of the problem prior to issuing the RMA number. All material must be pre-authorized before being returned.

See document 048-507-10 "Warranty and Repair Information" for more details.

Moving and Storage

Units must be suitably packed in the original shipping container (or equivalent) prior to re-shipping. The box should be completely enclosed and constructed of wood or double-wall, corrugated cardboard. At least 3" of foam or shock absorbing packing material must surround the unit.

Factory Service Centers

Canada and International

Argus Technologies Ltd.
ATTN: RMA Returns
7033 Antrim Avenue
Burnaby, BC, V5J 4M5 Canada
Tel: +1 604 436 5900
Fax: +1 604 436 1233
Email: returns@argusdcpower.com

USA

Argus Technologies Inc.
ATTN: RMA Returns
3116 Mercer Avenue
Bellingham, WA, 98225 USA
Tel: +1-360 756 4904
Fax: +1-360 647 0498
Email: returns-usa@argusdcpower.com

Asia-Pacific

PCM Electronics (Dong Guan) Co., Ltd.
Hongli Industrial Area, Miaobian, Liaobu Town,
Dongguan City, Guangdong Province,
523400 China
Tel: +86 755 8895 3310
Fax: +86 755 8895 3307

Authorized Service Center

Argentina

Argus Technologies de Argentina
Belen 315, Capital Federal, Buenos Aires,
14071 Argentina
Tel: +54 (11) 4672 4821
Fax: +54 (11) 4504 4698
Cell: +54 9 (11) 4993 9996
Email: ikleiman@argus.ca

Asia

Argus Technologies Asia Pte Ltd
Blk 6 Tagore Lane #160
Singapore 787570
Tel: +65 6458 8900
Fax: +65 6458 2122

Australia

CPS National
8/376 Newbridge Rd
Moorebank, NSW, 2170 Australia
Tel: +61 02 9822 8977
Fax: +61 02 9822 8077

Australia/New Zealand

Alpha Power Systems Pty Ltd
Unit 3, 30 Heathcote Road
Moorebank, NSW, 2170 Australia
Tel: +61 02 9602 8331
Fax: +61 02 9602 9180

Century Yuasa

37 - 65 Colbalt Street
Carole Park QLD 4300
Australian Sales & Service
Tel: +61 07 3361 6587
Fax: +61 07 3361 6705
New Zealand Sales & Service
Tel: +64 9 978 6689
Fax: +64 9 978 6677

Canada

Compower Systems Inc.
118 Tiffield Road
Toronto, ON, M1V 5N2 Canada
Tel: +1 416 293 3088
Fax: +1 416 293 0671

Europe

Alpha Technologies Europe Ltd.
Cartel Business Estate
Edinburgh Way
Harlow, Essex, CM20 2DU UK
Tel: +44 1279 422110
Fax: +44 1279 423355

Mexico & Central America

Technologies Argus First De Mexico SA de CV
Anatole France No. 17
Col. Polanco
Mexico City, 11560 Mexico
Tel: +52 55 5280 6990
Fax: +52 55 5280 6585

South America

Argus Technologies Argentina
Santo Tome 2573, Capital Federal
Buenos Aires, 1416 Argentina
Tel: +54 11 4504 4698
Cell: +54 9 11 4993 9996
E-pager: 541149939996@nextel.net.ar

Turkey

IPC Enerji Elk San ve TIC AS
Inonu cad. Kanarya sok. No:20
Yenisahra - Kadikoy
Istanbul, Turkey
Tel: +90 216 317 41 42
Fax: +90 216 472 90 66